



USER MANUAL

AC PowerCube 24/7000



Sine wave inverter

High power from your battery! Professional standalone true sine wave inverter

- Redundant heavy duty backup power system
- Lightweight 7kW sinewave inverter due to modern switch mode concept
- High surge power over 200%, allowing for inductive loads to start up smoothly
- Robust DC connections allow standard battery cables
- Energy saving by 90% system efficiency (peak)
- Compatible with WhisperPower DC PowerCube system

Thank you for purchasing the WhisperPower AC PowerCube Sinewave Inverter (WP-ACP). The WP-ACP allows you to produce 230V AC 'grid' voltage power from a battery. The WP-ACP actually consists of two (DC/DC) converters and a (DC/AC) inverter, all combined in one unit. The converters convert low battery voltages into high DC voltage; the inverter inverts the high DC voltage into a single phase sine wave AC ('grid') voltage.

TABLE OF CONTENTS

1. Introduction
2. Instructions for use
3. Troubleshooting
4. Installation
5. Warranty terms and conditions
6. Specifications
7. Conformity declaration

1. INTRODUCTION

Use of this manual

This manual serves as a guideline for safe and effective installation of the WP-ACP, as well as correct operation and, if necessary, troubleshooting. It is recommended to keep the manual in good condition for future use. It should be kept in a dry and clean place, and available any time.

General precautions

To ensure safe and sustainable operation of the AC PowerCube, it is obligatory that handling and safety instructions detailed in this manual are followed at all times. Every person working on or with the WP-ACP should be familiar with the contents of this document. Also bear in mind that all applicable (safety) standards and (local) regulations need to be followed at any time. Furthermore, only allow changes in your electrical system to be carried out by qualified electricians.



IMPORTANT!

Throughout this manual, the following alert symbol is used to indicate potential hazard:



CAUTION! Risk of equipment damage or personal injury: Always be aware of the fact that your actions may have an impact on safety and/or product performance. Carefully follow instructions documented.

2. INSTRUCTIONS FOR USE



CAUTION!

Risk of fire, explosion and/or electric shock
- To prevent overheating, NEVER block ventilation.

- NEVER smoke near the WP-ACP or allow flames or sparks in vicinity of batteries.
- Avoid inflammable goods near the WP-ACP.
- Make sure all cables meet specifications and are connected properly.
- Avoid sparks and/or short circuit; do not place metal tools on top of the batteries.
- Short circuit current may cause severe heat. Take off all personal metal / bullion rings, watches, bracelets etc. when working with batteries, as high temperatures may cause metal to melt.



CAUTION!

Risk of personal injury

- Follow the safety guidelines, as prescribed by the battery manufacturer, when working with batteries.

Rinse with extensive water in case battery acid would come in contact with your eyes or skin and seek medical attention.



CAUTION!

Risk of equipment damage

- Never disconnect any part of the wiring while the unit is in operation!

WP-ACP MAIN CONTROL DISPLAY

AC output section

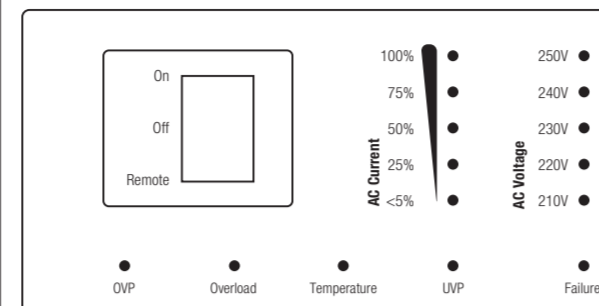

Use the main switch at the bottom left of the WP-ACP main control display to switch the system to 'On', 'Off' or 'Remote'.

As soon as the switch is set to 'On', the 'AC present' LED on top will illuminate and the inverter system will start supplying AC current. When switched 'Off', the system is shut down and AC current supply is stopped. Remark: don't forget to disconnect the batteries! Choose 'Remote' if you wish to operate the WP-ACP with the WP-RCP remote control panel. Use the AC current and voltage output status bars (next to the main switch) to monitor the WP-ACP output. The LEDs will indicate the AC output voltage (right), as well as the AC current load (left).



Five additional LED indicators at the bottom will illuminate in case of any error or exceptional condition occurring. If so, switch off the system first of all. The illuminated LED(s) will provide an indication of the nature of the problem. Use this information, together with the troubleshooting table in section 3, to trace and solve the problem.

OVP = Over Voltage Protection (Full Battery)

UVP = Under Voltage Protection (Low Battery)

DC input section

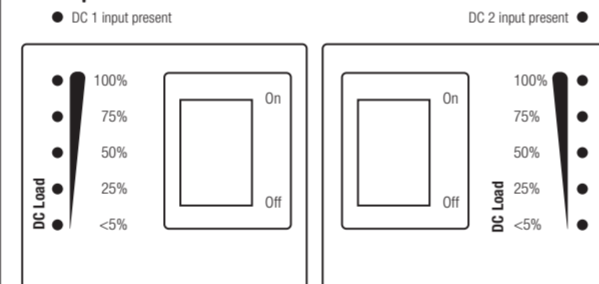

The top of the WP-ACP main display shows two DC battery monitoring sections; one for each battery bank. The two LEDs on top show whether one or both AC battery banks are operative. Note: as a result of redundancy design, the WP-ACP will still be able to produce AC current when only one battery bank supplies DC current. Use the switches to switch off DC supply from a battery bank - if needed -. The status bars demonstrate the load of the battery banks.

WP-RCP remote control panel

By setting the main switch on the main display to 'Remote', the WP-RCP becomes active.

Switch

Use the WP-RCP switch to power the system 'On' and 'Off'. Hold the button for approximately one second until the 'Inverter' LED illuminates. If pressed again (for one second), the system will be switched off, as visualised by the 'Inverter' LED.

AC output monitoring

Similar to the main display, the WP-RCP contains the AC current and voltage output status bars for AC output voltage (right) and AC current load (left) monitoring.

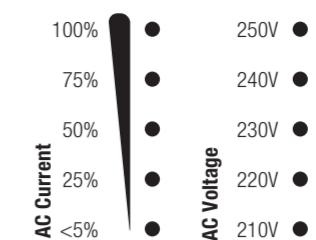

Error detection

In case of an error occurring, these LED indicators will help trace the cause of situation and solve the problem.

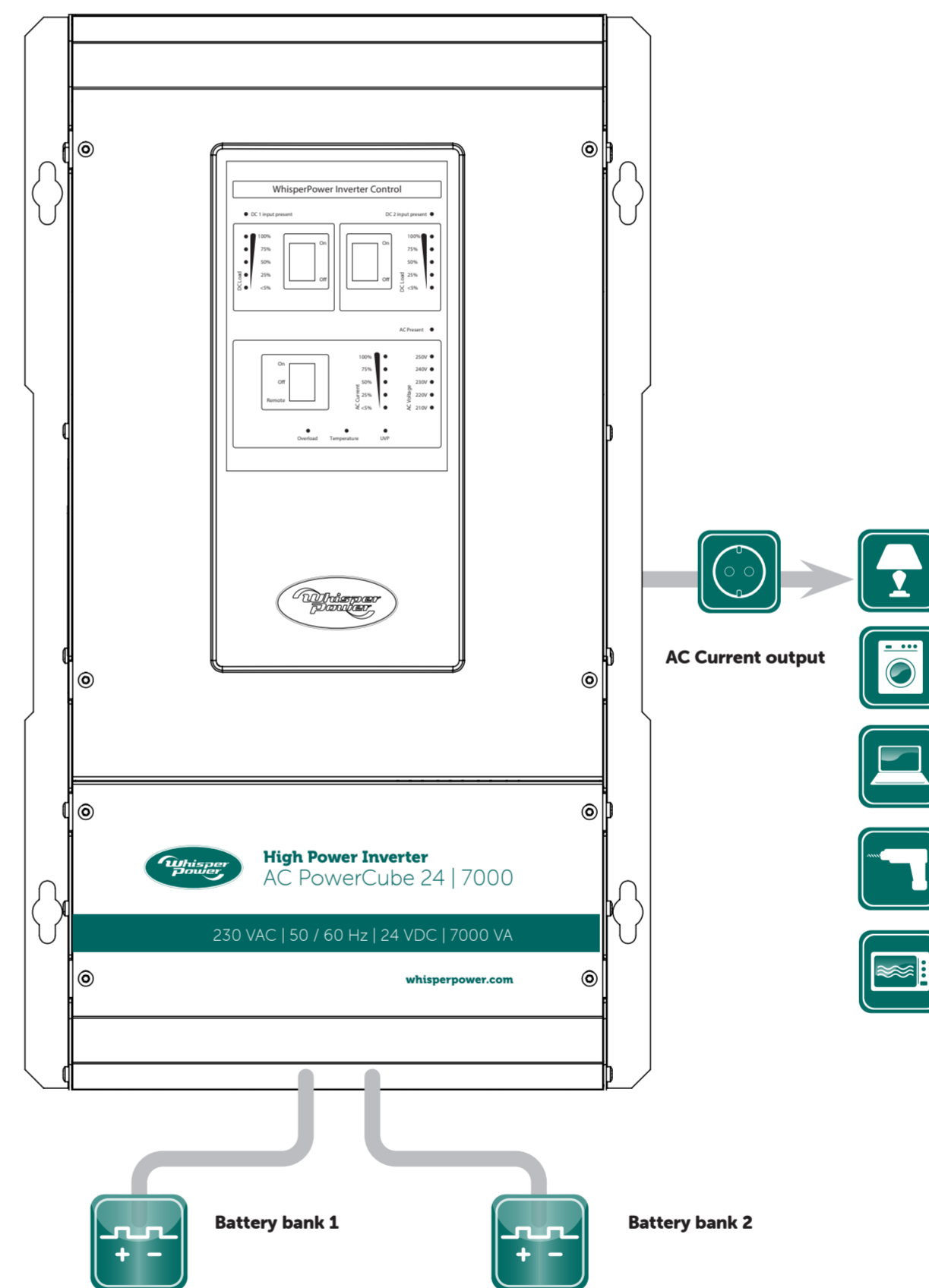
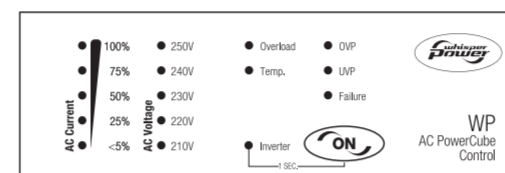
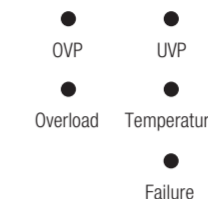

3. TROUBLESHOOTING

As described in section 2, the main display and remote control contain LED indicators which will illuminate in case of any exceptional situation or error occurring. If one or the alert LEDs is illuminated, this will give an indication of the source of the problem. The user is advised to switch off the system and try and correct the cause. Note that the system will switch off by itself in case of any error situation remaining for more than a few seconds.

PROBLEM	LED INDICATORS INFORMATION	POSSIBLE CAUSE	SOLUTION
No AC output	None of the main display LED indicators illuminated	Main switch set to 'Remote', but no remote panel installed	Set main switch to 'On' and/or install remote
		Battery voltage too high	Check battery voltages and replace if necessary
		DC fuse blown	Install new fuse
	'DC load' LED bars are off; LED 'UVP' may be illuminated	No battery input	Check the batteries and charge if necessary; the unit will automatically restart when battery voltage reaches 22V
		Battery too low	Charge the batteries; the unit will automatically restart when battery voltage reaches 22V
		Cables too thin	Replace with cables of correct diameter
WP-ACP switches on and off; ventilator is running at full speed		Bad / corroded connections	Tighten the connections; check the cables and replace when burned
	'Overload' LED is illuminated; 'Temperature' LED may also be lit	The unit has switched off due to too high AC demand	Reduce the load and allow the unit to cool down
	LED 'Temperature' is lit	Working temperature too high	Make sure ventilation is not obstructed anywhere and check the ventilator; if necessary, move the unit to a colder location and/or reduce the load
	LED 'AC Present' on the main display and 'inverter' on the remote are blinking; same goes for the 'UVP' LED	Battery too low	Charge the batteries; the unit will automatically restart when battery voltage reaches 22V
		Cables too thin	Replace with cables of correct diameter
		Bad / corroded connections	Tighten the connections; check the cables and replace when burned
WP-ACP switches on and off; ventilator is running at full speed	LED 'AC Present' on the main display and 'inverter' on the remote are blinking once every second; same goes for the 'overload' LED	Too high AC demand	Reduce the load
	LED 'AC Present' on the main display and 'inverter' on the remote are blinking five times per second; same goes for the 'overload' LED	Unit has been switched off ten times in a row as a result of an overload situation or a short circuit	Reduce the load and solve the short circuit situation; reset the unit manually by means of the On/Off switch

Disclaimer

WhisperPower can accept no responsibility for possible errors or omissions in catalogues, brochures and other printed material. WhisperPower reserves the right to alter its products without notice. This guide must be followed carefully. WhisperPower can accept no responsibility for errors related to incorrect or unsafe installation and/or handling.

4. INSTALLATION

CAUTION!

Risk of fire, explosion and/or equipment damage

- The WP-ACP has been designed for indoor use. Do not expose the system to dust, rain, snow or liquids of any type.
- NEVER obstruct ventilation airflow in any way. Keep a free space of 200mm around the system.
- Never place the unit directly above the batteries; corrosive gases emerging from batteries have a damaging impact.
- Check the battery identification labels prior to installation: be sure that the battery voltages match the input voltage of the DC/DC-converters.

Installation prerequisites

- Mount the WP-ACP—indoors—on a solid wall. Position the system as indicated below: vertically, with the connecting cables downwards.
- When the system is to be installed in a cabinet, make sure that the control panel remains accessible.
- Use DC battery cables of at least 70mm².
- Always integrate a fuse when connecting the batteries.
- Protect the equipment to be supplied by the WP-ACP output by AC-fuse of 16Amps maximum.

Materials

The WP-ACP system includes:

WP-ACP AC PowerCube

Remote control panel

Step 2: Connecting input and output cables

The drawing below presents a tilted view of the WP-ACP connectors section which can be accessed when opening the hinged flap at the bottom. Connect cables for the AC output, as well as for the batteries, as documented. It is recommended to use cable of 70 mm² minimum for the batteries; use the cable glands at the bottom to guide the cables.

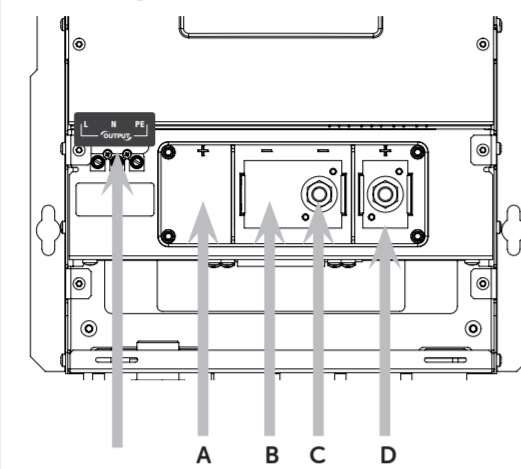

- Output 'grid AC'**
Including neutral bounding:
Disable the N - PE connection
- on the PCB - if preferred without neutral bounding
- A Input battery bank 1 (plus)
 - B Input battery bank 1 (minus)
 - C Input battery bank 2 (minus)
 - D Input battery bank 2 (plus)

Output 'grid AC'

Including neutral bounding:
Disable the N - PE connection
- on the PCB - if preferred without neutral bounding

Step 3: Realise PCB ports connections
The picture below presents a detailed (bottom) view of the connectors section, showing the PCB print circuit board connectors:

Explanation of the PCB ports and configuration:

- External command** (Phoenix MSTBA2/4-G-5.08)
 - 1 GND
 - 2 Switch
 - 3 On LED
 - 4 Failed LED
- Remote control panel**
RJ12 port, to be connected by RJ12 cable to the remote control panel; connect one end of the cable to this PCB port and the other to the RJ12 port of the remote panel (please note the polarity)
- WhisperConnect CAN-Bus**
RJ45 port for integration of multiple WhisperPower systems
- USB Type 2**
Use this port to set output parameters

DIP switch 1-8
Refer to diagram below for an overview of the DIP switch parameters. DIP switch settings can also be programmed by the USB computer interface; in that case all parameters should be set to 'OFF'.

Relay NC/NO/COM
Returns system status → ON or OFF

Relay NC/NO/COM
Returns error status → No Error or Error
NB: only applicable when status = ON

Digin1
Connect this port to your computer interface to be able to use the interface instead of remote panel remote switch

Digin2 Additional, not connected

Step 1: Positioning the WP-ACP housing

Determine the housing mounting points; dimensions are presented in drawings below. Use screws / bolts of Ø 6mm. Start by driving the screw tips into the wall, but do not tighten completely. Then place the WP-ACP housing over the screws and fix by fastening the screws securely.

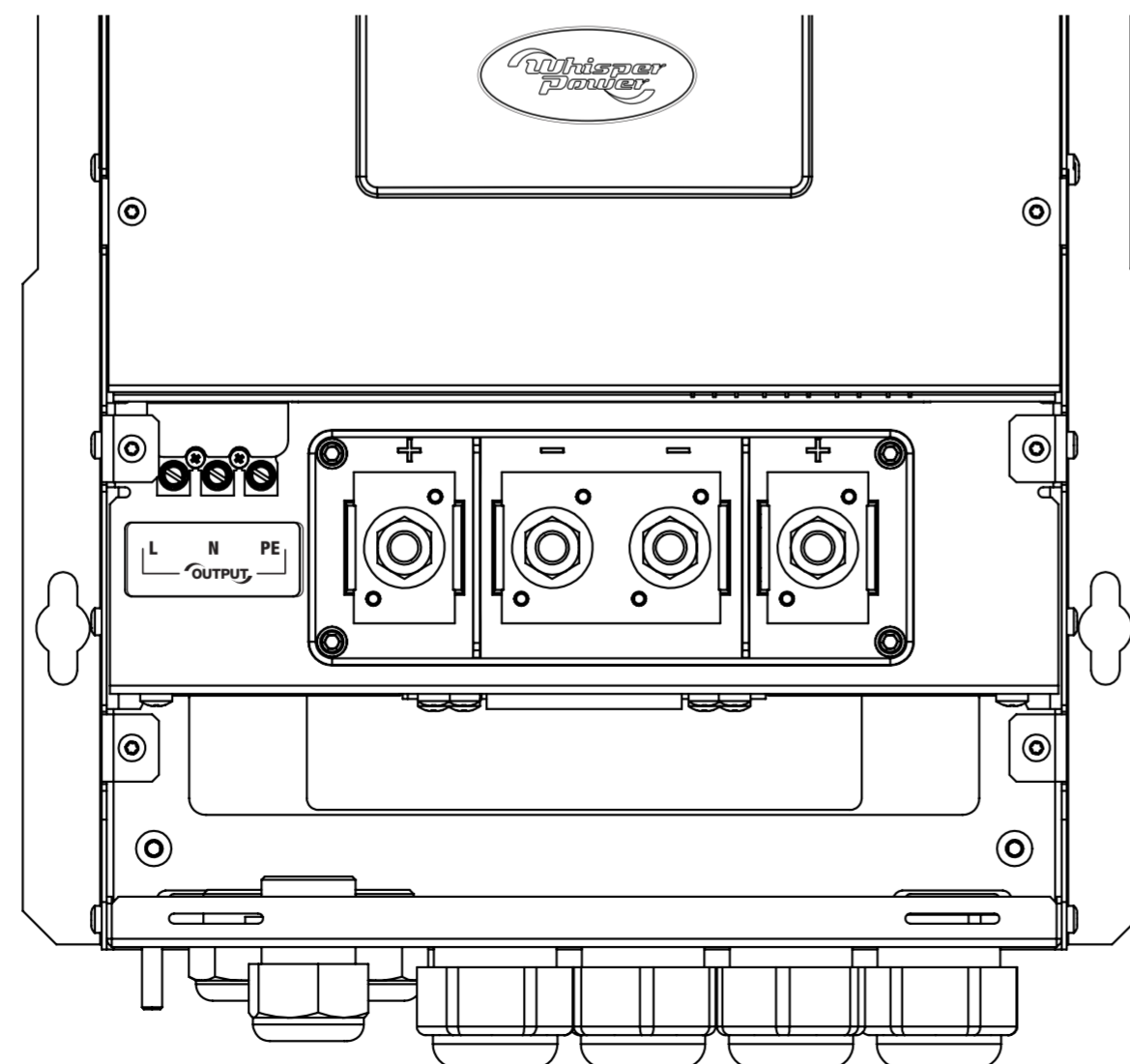
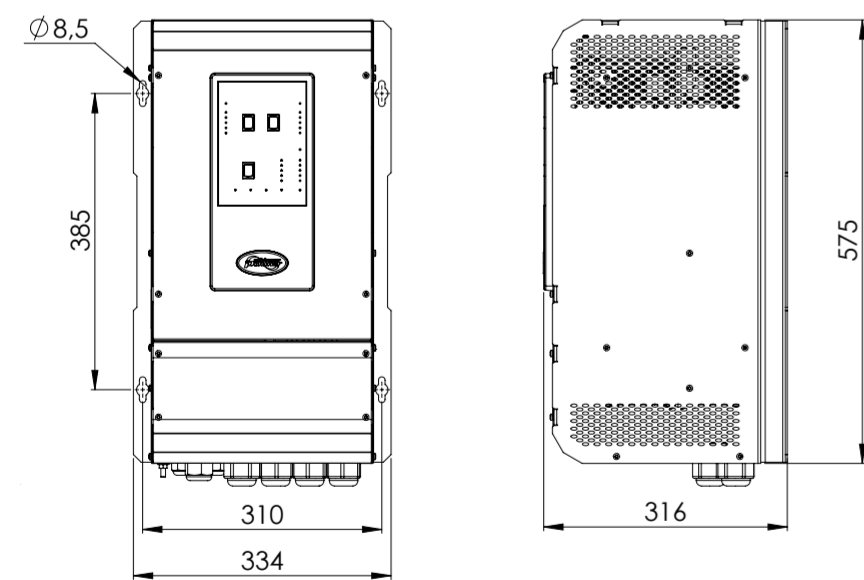

Step 4: Connecting and positioning remote control

The remote panel can either be mounted on the surface (frame, wall, dashboard) or it can be counter-sunk in your frame or dashboard. If the remote panel is to be mounted on top of the surface, the back cover can be used as a drill guide:

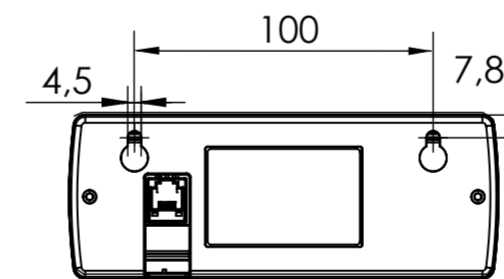

In case the remote panel is to be mounted in the dashboard: the following drawing presents cutout dimensions:

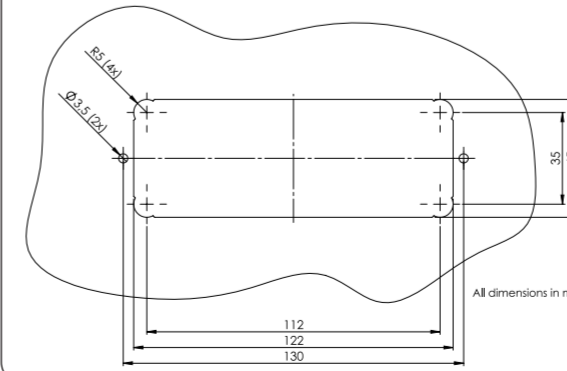

5. SPECIFICATIONS

Article Nr.

AC POWERCUBE 24/7000

60203004

GENERAL

Nominal output voltage	230 V (± 5%), Phase, Nil, Earth
Nominal output frequency (adjustable)	50 Hz (± 0,01Hz)
Nominal battery voltage	24 V (+ and - connection)
Nominal power P30 (cos phi = 1) (30 min at 40°C)	7500 W
Peak power (20 s)	15000 W
Continuous power (cos phi = 1) (40°C)	6000 W
AC connection (output)	Internal terminal block, screw terminal (4 .. 6 mm ²)
DC connection	4 x M10
Minimum capacity of battery bank	600 Ah
Efficiency	> 85%
Peak efficiency	> 92%
Dimensions (Length x width x height - mm)	334 x 316 x 575
Weight	18kg
Noise level (at 1m)	< 48dBA

Operation
Power switch (on / off / remote), the DC inputs (on / off), Remote panel switch (On / Off) *

Indicators
AC present, DC 1 present, DC (1) load, DC 2 present, DC (2) load, AC current, AC voltage

Safety
Short circuit, overload, overheating, battery voltage too low / high

TECHNICAL SPECIFICATIONS

Technology	Six-step multiphase flyback, switching technology
Low battery switch off	19 V (± 0.5 V)
Low battery switch on	22 V (± 0.5 V)
High battery switch off	32 V (± 0.5 V)
High battery switch on	30 V (± 0.5 V)
Maximum ripple on DC (battery)	5% RMS
Input current (nominal load)	2 x 200 A
Consumption (no load)	< 550 mA, 12 W
Total harmonic distortion (THD)	< 5% (normal)
Allowable power factor	0 < cos phi < 1

CONDITIONS

Ambient operating temperature	-20°C .. 40°C
Storage temperature	-25°C .. 80°C (derating above 40 °C)
Relative humidity	Max 95%, non-condensing
International Protection rating	IP23

Cooling

CONFORMITY

EU Directive
EMC Directive 2004/108 / EC, EMC 2004/104 / EC (automotive), Low Voltage Directive 2006/95 / EC

Standards
EN 55022 (emission) EN 61000-3-2 (harmonic distortion), EN 61000-4-11, EN 61000-3-3 (voltage variations), EN 61000-6-2 (immunity) and EN 60950-1 (safety) AND 68-2-6 (vibration), EN 60945 (navigation and radio communications), UL 458

6. WARRANTY TERMS AND CONDITIONS

WhisperPower guarantees that the equipment has been built according to the legally applicable standards and specifications. WhisperPower assures the product warranty of the WP-ACP AC PowerCube sine wave inverter during two years after purchase, on the condition that all instructions and warnings given in this manual are taken into account during installation and operation. The warranty is limited to the costs of repair and/or replacement of the product by WhisperPower only. Costs for installation labor or shipping of the defective parts are not covered by this warranty.

7. CONFORMITY DECLARATION

Issuer's name: WhisperPower BV
Issuer's address: Kelvinlaan 82, NL-9207 JB Drachten
Object of the declaration: AC PowerCube 24/7000
Sine wave inverter Model no. 60203004
The object of the declaration described above is in conformity with the requirements of the following Directives and standards, as applicable: 2004/108/EC (EMC Directive); EN 55022:2010, EN 60945:2002, EN 61000-3-2:2006, EN 61000-3-3:2013, EN 61000-4-11:2004, EN 61000-6-2:2005; 2006/95/EC (Low Voltage Directive); EN 60335-1:2012, EN 60335-2-29:2004, EN 60950-1:2006; Standard conformity; EN 60068-2-6:2008, UL 458.
Signed for and on behalf of: WhisperPower BV

Drachten,
M. Favot, C.T.O.
WhisperPower B.V.

