

User Manual

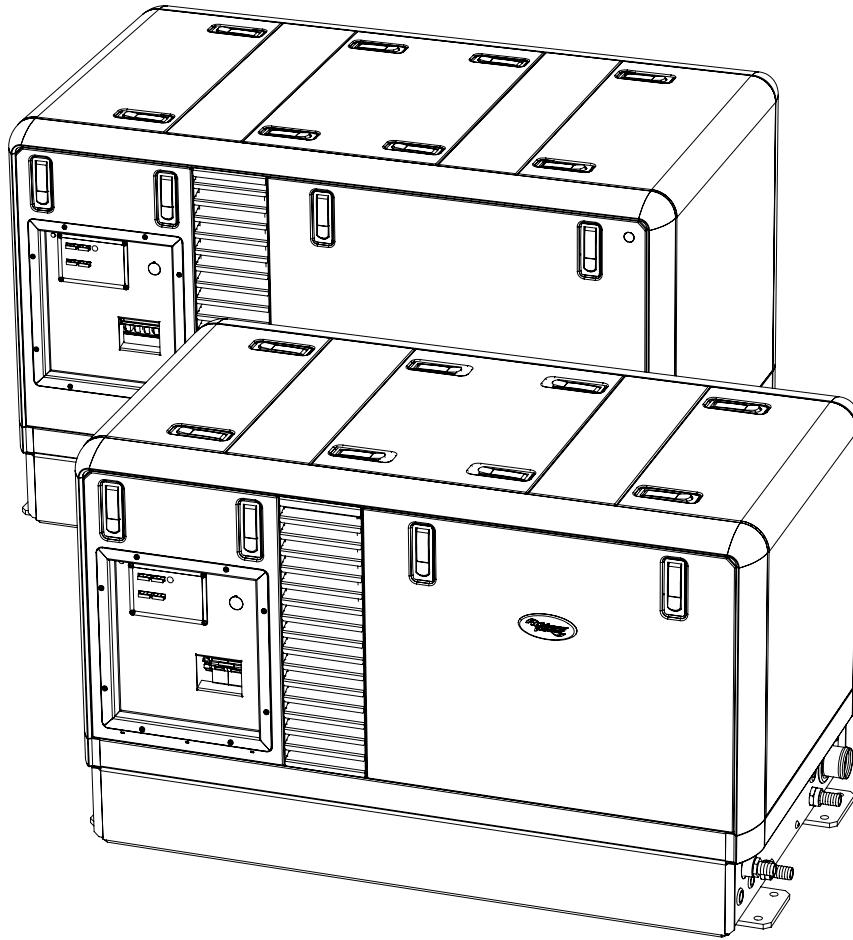

Marine Diesel Generator M-SQ Pro

15 kVA | 18 kVA | 1500 RPM | 230/400 V | 50Hz | 1phase / 3phase

whisperpower.com

CONTENTS

| | | |
|----------|---|----------|
| 1 | INTRODUCTION | 4 |
| 1.1 | General..... | 4 |
| 1.2 | Service and maintenance | 4 |
| 1.3 | Guarantee | 4 |
| 1.4 | Liability | 5 |
| 1.5 | Identification | 5 |
| 1.5.1 | General..... | 5 |
| 1.5.2 | Identification plate..... | 5 |
| 2 | INFORMATION..... | 6 |
| 2.1 | Safety..... | 6 |
| 2.1.1 | General..... | 6 |
| 2.1.2 | Electrical safety | 6 |
| 2.1.3 | Earth insulation failures | 6 |
| 2.1.4 | Installation..... | 7 |
| 2.1.5 | Operation | 7 |
| 2.1.6 | Fire and explosion..... | 7 |
| 2.1.7 | Chemicals | 7 |
| 2.2 | Transport, lifting and storage..... | 7 |
| 2.3 | M-SQ-Pro15 and M-SQ-PRO 18..... | 8 |
| 2.3.1 | Features | 8 |
| 2.3.2 | Remote control | 8 |
| 2.3.3 | Documentation | 8 |
| 2.4 | Components..... | 9 |
| 2.4.1 | Main components to identify | 9 |
| 2.4.2 | Generator control panel | 11 |
| 2.4.3 | Remote control panel | 11 |
| 2.5 | Technical Information | 11 |
| 2.5.1 | AC alternator..... | 11 |
| 2.5.2 | Engine | 11 |
| 2.5.3 | Digital Diesel Control system | 11 |
| 2.5.4 | Battery charger | 12 |
| 2.5.5 | Alarms and shut down | 12 |
| 2.5.6 | Monitoring | 12 |
| 2.5.7 | Control | 12 |
| 2.5.8 | Remote control | 12 |
| 2.5.9 | Hour counter | 12 |
| 2.5.10 | Load indicator | 12 |
| 2.5.11 | Fuel specification | 12 |
| 2.5.12 | Oil information | 12 |
| 2.5.13 | Cooling liquid | 13 |
| 2.5.14 | Technical data | 14 |
| 2.5.15 | WIRING CODES AND COLORS | 15 |
| 2.5.16 | Lay out control wiring M-SQ PRO 15 1-Phase Kubota | 18 |
| 2.5.17 | Lay out control wiring M-SQ PRO 15 1-Phase Kubota | 19 |
| 2.5.18 | Lay out control wiring M-SQ PRO 15 1-Phase Kubota | 20 |
| 2.5.19 | Lay out control wiring M-SQ PRO 15 3-Phase Kubota | 21 |
| 2.5.20 | Lay out control wiring M-SQ PRO 15 3-Phase Kubota | 22 |
| 2.5.21 | Lay out control wiring M-SQ PRO 15 3-Phase Kubota | 23 |
| 2.5.22 | Lay out control wiring M-SQ PRO 18 1-Phase Kubota | 24 |
| 2.5.23 | Lay out control wiring M-SQ PRO 18 1-Phase Kubota | 25 |
| 2.5.24 | Lay out control wiring M-SQ PRO 18 1-Phase Kubota | 26 |

2.5.25 Lay out control wiring M-SQ PRO 18 3-Phase Kubota 27

2.5.26 Lay out control wiring M-SQ PRO 18 3-Phase Kubota 28

2.5.27 Lay out control wiring M-SQ PRO 18 3-Phase Kubota 29

3 OPERATION 30

3.1 General..... 30

3.2 Operating Instructions 30

3.2.1 Summarized operating instructions (daily use)..... 30

3.2.2 Extended operating instructions 30

4 MAINTENANCE 32

4.1 Alternator..... 32

4.2 Engine..... 32

4.2.1 Preliminary instructions..... 32

4.2.2 Bleeding fuel lines..... 32

4.2.3 Valve clearance 32

4.2.4 Replacing fuel filter 32

4.2.5 Replacing oil filter 32

4.2.6 Tensioning V-belt..... 33

4.3 Regular maintenance 33

4.3.1 Maintenance schedule 34

4.3.2 Taking out of service 34

5 TROUBLESHOOTING 36

5.1 Alternator/ electrical faults..... 36

5.1.1 General..... 36

5.1.2 Troubleshooting table 38

5.2 Engine faults..... 39

5.2.1 General..... 39

5.2.2 Troubleshooting table 40

5.2.3 Warnings 43

5.2.4 Service address 43

5.3 Special procedures alternator 43

5.3.1 Automatic Voltage Regulator (AVR)..... 43

5.3.2 Residual voltage check / excitation procedure (flashing) 43

5.3.3 Testing rotary rectifier diodes 44

5.3.4 Winding resistant values 44

5.3.5 Meggering 44

5.4 Special procedures engine..... 44

5.4.1 Setting the RPM 44

5.4.2 Adjusting valve clearance and retightening the cylinder head bolts 45

5.4.3 Measuring exhaust backpressure 45

5.4.4 Disassembling instructions 46

6 SPARE PARTS 48

6.1 40201670 Raw Water Pump SQ-Pro 15 49

6.2 42401870 Raw Water Pump SQ-Pro 18 50

7 MAINTENANCE LOG..... 51

1 INTRODUCTION

1.1 General

The M-SQ-Pro 15 and M-SQ-Pro 18 Marine Diesel Generating sets are manufactured and marketed by WhisperPower.

It is important to read this manual before installing and operating the generating set. Both safety and durability rely very much on the correct identification, installation and a good understanding of ratings, features, design, maintenance and operation procedures.

The information, specifications, illustrations and statements contained within this publication are given with our best intentions and are believed to be correct at the time of going to press.

All of the specifications, provisions and instructions contained in this manual apply solely to standard versions of the M-SQ-Pro 15 and M-SQ-Pro 18 generating set.

This manual is valid for the following models:

| Part number | Description |
|--------------------|--|
| 41207005/ 41207305 | M-SQ-Pro 15 230- 400V / 50 Hz 1phase / 3phase, 1500rpm, Mobile |
| 41208105/ 41208305 | M-SQ-Pro 18 230- 400V / 50 Hz, 1phase / 3phase, 1500rpm, Mobile |

See 1.5 for identification of the generator set.

For other models see other manuals available on our website: www.whisperpower.com

Our policy is one of continued development and we reserve the right to amend any technical information without prior notice.

Whilst every effort is made to ensure the accuracy of the particulars contained within this publication neither the manufacturer, distributor, or dealer in any circumstances shall be held liable for any inaccuracy or the consequences thereof.



WARNING

A warning symbol draws attention to special warnings, instructions or procedures which, if not strictly observed, may result in damage or destruction of equipment, severe personal injury or loss of life.



DANGER

This danger symbol refers to electric danger and draws attention to special warnings, instructions or procedures which, if not strictly observed, may result in electrical shock which will result in severe personal injury or loss of life.

1.2 Service and maintenance

Regular service and maintenance should be carried out according to the directions in this manual. For service and maintenance one can appeal to the manufacturer or the dealers.

1.3 Guarantee

WhisperPower guarantees that this generating set has been built according to good workmanship, according to the specifications in this manual and according to European Community safety regulations.

During production and prior to delivery, all of our generating sets are tested and inspected.

This generating set's correct operation is subject to guarantee. The period and conditions of this guarantee are laid down in the general conditions of delivery as registered with the Chamber of Commerce and Industries for the North of the Netherlands number 01120025. The guarantee period is two years, limited to 1000 running hours. Some aspects of our guarantee scheme are given here in more detail:

Guarantee does not cover failures that are caused by misuse, neglect or a faulty installation.

Example 1. Faulty installation:

Seawater entering the engine is the most common cause of damage to combustion engines in boats. (Both to propulsion and generator engines.) The entry of water must be avoided under all conditions. Be aware that the conditions in blue water sailing can be extreme. See the installation manual for instructions but remember these are for guidance only as many factors influence the installation of a generator. The ultimate responsibility will always be with the owner to ensure a safe and compliant installation.



WARNING

Damage caused by the ingress of water is never covered by guarantee.

Example 2: Misuse:

Long term running with no load or too little load can cause the exhaust to get choked with soot or carbon. Cleaning the exhaust is not covered by guarantee.

Example 3: Neglect

Sometimes the seal of the raw water pump starts leaking. Mostly this begins with a little drip and slowly gets worse. Regular visual inspection of the generator is necessary to prevent damage to occur from a leaking water pump. When one find serious damage after weeks of neglect guarantee claims will not be honored.

Example 4: Neglect

Whisper generators have an option for an auto start/stop mode or interval mode.

WhisperPower cannot be held responsible for damage caused by the unattended running generator.

Guarantee means that faulty parts are repaired or replaced free of charge. If necessary the whole generator unit will be exchanged. Labour necessary to complete repairs on board a vessel executed by an authorized service engineer is covered, but is limited to a reasonable number of hours and reasonable rates in relation to the actual repair work that has to be done.

Travel expenses and travel hours are not covered. Also not covered is the labour required to take a generator out of a boat or for reinstallation. There is no cover for labour needed to get access to the generator, for example to remove equipment or bulkheads etc.

Goods to be delivered under guarantee will be invoiced. Only after the faulty goods are returned will the invoice be credited. Payment in advance may be required or guaranteed by credit card. If after the faulty goods are returned, it is indicated that the failure was not covered by guarantee a credit will not be issued. For example if a Printed Circuit Board is returned with clear damage caused by seawater, guarantee will be refused.

Freight costs to deliver spares by normal mail or carriers is covered under guarantee. Special services like express mail, overnight delivery etc. are not covered. Taxes and duties are not covered. For shipments to remote off shore areas any additional costs incurred over normal carriage will be invoiced to the customer.

The cost for returning faulty goods is not covered under guarantee.

1.4 Liability

WhisperPower does not accept responsibility for damage, injuries or casualties which are the result of operation of the generating set in specific conditions which brings dangers which could not be foreseen, or could be avoided by additional measures. WhisperPower does not accept liability for damage due to use of the generator, possible errors in the manuals and the results thereof.

Automatic start/stop

WhisperPower cannot be held responsible for damage caused by the unattended running generator using the auto-start/stop mode or interval mode.

1.5 Identification

1.5.1 General

Before using this generating set it is very important to identify the set correctly. To communicate for service or ordering parts it is also essential to correctly identify the generating set. Also for the daily operation of the generating set it is necessary that the operator knows the correct specifications.

1.5.2 Identification plate

All required identification data are on the identification plate

| WhisperPower | |
|---|---------------------|
| Model: | M-SQ Pro 18 |
| Article nr: | 41208105 |
| Serial nr: | P329A0010 |
| Nominal Power: | 16 kW |
| Configuration: | 1 Phase 3 Wires |
| Voltage: | 230 V |
| Frequency: | 50 Hz |
| Current: | 71 A |
| Dimensions L x W x H: | 1220 x 720 x 752 mm |
| Weight: | 512 Kg |
| Made in The Netherlands Manufacturer: WhisperPower b.v. Kelvinlaan 82, 9207 JB Drachten, The Netherlands Tel. +31 (0)512-571550 | |
|  | |

Fig. 1: Identification plate

- The identity of the generating set is given by the SERIAL NUMBER. When this number is available the manufacturer can trace the specifications of the generating set. On the nameplate are also some basic features of the set:

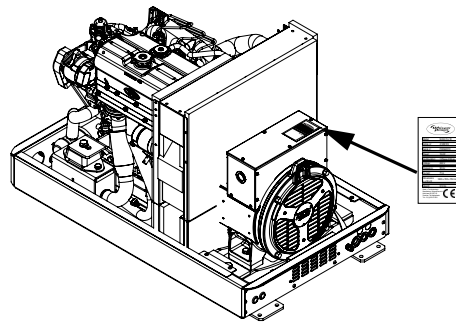

Fig. 2: Location identification plate

- POWER

The nameplate gives the nominal maximum continuous load in kVA = kW calculated with power factor one. When calculating a load one should always take into account the power factor or $\cos \phi$ of this load. The power should never exceed the nominal power as shown on the nameplate. Power is rated at an ambient temperature of 25°C and a seawater temperature of 15°C. For higher temperatures the generating set has to be de-rated.

- 3 **VOLTAGE.** This shows the nominal voltage.
This voltage should be within the specified tolerance at the nominal frequency. The M-SQ-Pro15/18 can be connected for different voltages in single phase or tri phase. The nameplate indicates the connection as made in the factory.
- 4 **FREQUENCY.** This is shown in Hz and is determined by the speed of the engine (RPM). 50 Hz correlates with 1500 rpm.
- 5 **CURRENT.** This shows the maximum current that is acceptable at the specified frequency, voltage and power factor. When connected in tri phase the indicated current is the current between two phases that can be taken off three times.
- 6 **WEIGHT** shows the net dry weight (approximately) in kg. This is without fuel, oil, packing and external installation equipment
- 7 **CE MARKING.** The CE symbol shows that the generating set is build according to European Community safety regulations. This includes the regulations regarding the safety of pleasure craft, safety of machinery, regarding electric safety and electric magnetic compatibility (EMC).

Safety also relies on the installation, application and circumstances. See also the remarks in this manual under SAFETY.

Before changing a factory setting you are advised to consult the manufacturer. When the generating set you have to identify is not new you have to take into account the possibility that former users did change the settings. Check the settings (voltage, frequency, rpm) when there is any doubt.

2 INFORMATION

2.1 Safety

2.1.1 General

When correctly installed and used in normal circumstances this generating set fulfills EC safety regulations. This generating set could be part of an installation or could be used in a way that additional regulations of the EC or other authorities have to be taken into account.



DANGER

Warning signs draw attention to special warnings, instructions or procedures which, if not strictly observed, may result in electrical shock which will result in severe personal injury or loss of life.

Circumstances could make it also necessary to take additional measures. Be aware of wet conditions and hazardous environments caused by explosive gases etc.

2.1.2 Electrical safety



This warning sign indicates parts which could be live. The voltage of 230V or 230V/400V generated by this generating set is dangerous and if instructions and procedures are not strictly observed may result in electrical shock which will result in severe personal injury or loss of life.

- Check all wiring at least once a year. Defects, such as loose connections, burned cables etc. must be repaired immediately.
- Do not work on the electrical system if it is still connected to a current source. Only allow changes in your electrical system to be carried out by qualified electricians.
- Using the auto-start/stop (interval) mode the generator can start unexpectedly. When working on the electrical system, the 3 Amp Digital Diesel Control fuse must be removed from the control panel and the battery plus cable must be removed from the battery.
- Connection and protection must be done in accordance with local standards.

2.1.3 Earth insulation failures

According to local regulations and depending on the application it could be necessary to take measures for protection against earth insulation failures.

In the standard delivery “neutral” and “ground” are not connected. To make a connection between “neutral” and “ground” could be necessary as part of a specific insulation failure protection system.

Small pleasure craft in Europe is submitted to The Recreational Craft Directive 94/25/EC. The guidelines of this directive refer to (ISO 13297).

When the installation complies with this standard the “neutral” and “ground” should be connected on the generating set.

Be aware that insulation protection systems can be different for different applications and even within the ship there could be different standards for different spaces. We did refer to the Recreational Craft Directive that applies to pleasure craft up to 24 m of length. Sometimes one has to comply with other standards such as the rules of certification societies like Lloyd’s Register of Shipping or Veritas, regulations for the protection of personal, building legislation, etc. It is of the greatest importance to have expert advice on this issue.



In all situations the transfer switches between shore, inverter and generator should switch both neutral (N) and all phase lines (L1, L2 and L3).

2.1.4 Installation

Whisper generating sets are not self-contained and have to be properly installed in enclosed areas such as a machine room.



Installation includes measures to be taken to outlet exhaust fumes which contain carbon monoxide and are extremely dangerous.

Carbon monoxide (CO) is an invisible odorless gas. Inhalation produces headache, nausea or death. Installation includes measures for proper ventilation, safe electric connections, safe installation of the starting battery, proper fitting of the cooling system and fuel pipes etc. See the installation manual.

2.1.5 Operation

External moving parts like fans and V-belts are covered by the canopy and therefore the M-SQ-Pro15/18 is very safe when the canopy is closed.



Nevertheless take note of the signs on the generating set which show symbols in a triangle indicating danger.



When service has to be carried out while the engine is running, be aware of moving parts like V-belts.

- The generating set should be operated by authorised personnel only.
- Be aware of hot parts and especially parts of the exhaust system and cooling system.
- If the generating set is unsafe, fit danger notices and disconnect the battery positive (+) lead so that it cannot be started until the condition is corrected.
- Do not attempt to operate the generating set with a known unsafe condition. Disconnect the battery positive (+) lead prior to attempting any repairs or cleaning inside the enclosure.
- Always consult the manual before carrying out maintenance.
- Do not change the settings without consulting the manufacturer. Keep a record of setting changes in this manual.

2.1.6 Fire and explosion



Fuels can be flammable. Proper handling limits the risk of fire and explosion.

- Avoid refilling the fuel tank while the engine is running. When oil or fuel is leaking do not use the generating set.
- Do not run the engine close to explosives or gasses.
- Hydrogen gas generated by charging batteries is explosive. Take measures for proper ventilation. Do not smoke or allow sparks, flames, or other sources of ignition around batteries.
- Keep a fire extinguisher on hand.
- Poor electrical connections or using wiring which is not suited for the rated currents can cause overheating and possibly fire.

2.1.7 Chemicals

- Fuels, oils, coolants, and battery electrolyte can be hazardous to personnel if not treated properly. Do not swallow or have skin contact with these liquids. Do not wear clothing that has been contaminated by fuel or lubricating oil.
- Gaskets may be manufactured from asbestos. Particles of this material should not be inhaled as this may result in fatal diseases.
- On no account allow any unprotected skin to come into contact with the injector spray as the fuel may enter the blood stream with fatal results.
- Engines may be fitted with seals or O-rings manufactured from "viton" or similar material. When exposed to abnormal high temperatures in excess of 400°C an extremely corrosive acid is produced which cannot be removed from the skin. If signs of decomposition are evident, or if in doubt, always wear disposable heavy duty gloves.

2.2 Transport, lifting and storage



When lifting the generating set avoid any risk of personal injuries, do not stand under the generating set.

- Use soft slings to avoid damage
- On the engine are lifting eyes, which can be used to take the generator out of the capsule. The lifting eyes can also be used to lift the entire generator set, including the capsule
- After transporting the generating set check for damage before installation.
- Long term storage can have detrimental effects on engine and alternator. The engine should be put through an engine preservation procedure. (See the maintenance chapter)
- The alternator windings tend to condense. To minimise condensation, store the generating set in a dry and warm storage area.
- After removing the generating set from long term storage perform an insulation check. (See the alternator maintenance paragraph for procedures)
- While the battery is stored it should be recharged every 12 weeks.

2.3 M-SQ-Pro15 and M-SQ-PRO 18

2.3.1 Features

This generating set includes a 4 cylinder diesel engine which is connected by close coupling to a one or three phase synchronous alternator in a sound attenuated capsule. The set is mounted on a steel base frame and mounted securely on anti-vibration mounting pads to the capsule base. The complete set is again on rubber mountings. All cables and hoses are guided through the capsule's sides. The set is not self-contained and is only operable after proper installation using additional accessories and installation materials.

Installation accessories are listed in the installation manual and are available through the supplier of the generating set. The full automatic Digital Control is based on microprocessor technology. Several automatic start/stop functions can be programmed and monitored (see Digital Diesel Control user manual).

2.3.2 Remote control

The full automatic remote control panel including 15 mtr cable comes as standard with the Whisper generating M-SQ-Pro 15 / 18.

2.3.3 Documentation

Included in the delivery are:

- User manual generator
- Installation manual generator
- Manual DDC
- Test form
- Commissioning form
- 2x type plate

In this manual there is a list of important parts for maintenance and spare parts as well as a chapter on maintenance and problem solving.

All manuals are available on our website www.whisperpower.com.

2.4 Components

2.4.1 Main components to identify

1. Battery "black" 35mm²
2. Battery "red" 35mm²
3. Air inlet
4. Earth lug M10
5. AC cable 3G 10mm² (1phase)
AC cable 4G 6mm² (2phase)
AC cable 5G 4mm² (3phase)
6. Communication cable
7. Fuelpump powercable
8. Fuses
9. Local Control Panel
10. Circuit breaker
11. Emergency stop *option
12. Fuel out 8mm
13. Syphon in hose 3/4"
14. Fuel in 8mm
15. Water in hose 3/4"
16. Drain
17. Syphon out hose 3/4"
18. Exhaust
Marine: Ø50 hose con.

SQ- Pro 15

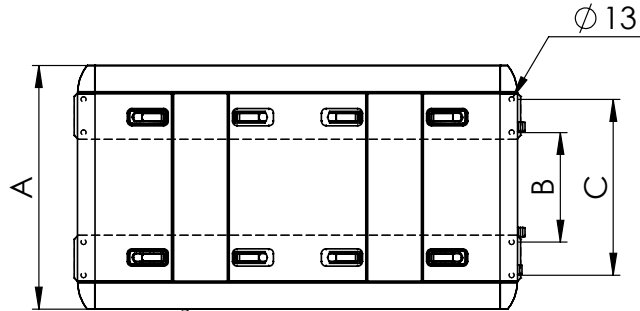

19. Air filter
20. Oil fill
21. Lifting eye
22. V-belt
23. Accelerator
24. Waterpump
25. Exhaust
26. Oil filter
27. Dynamo
28. Temperature sensor
29. Coolant fill
30. Manifold
31. Starter motor

- A. 625 mm
B. 281 mm
C. 451 mm
D. 690 mm
E. 1129 mm
F. 1098 mm
G. 1145 mm

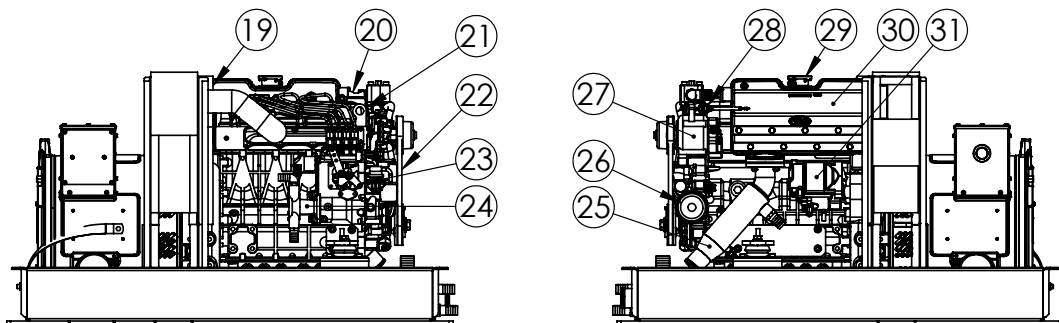
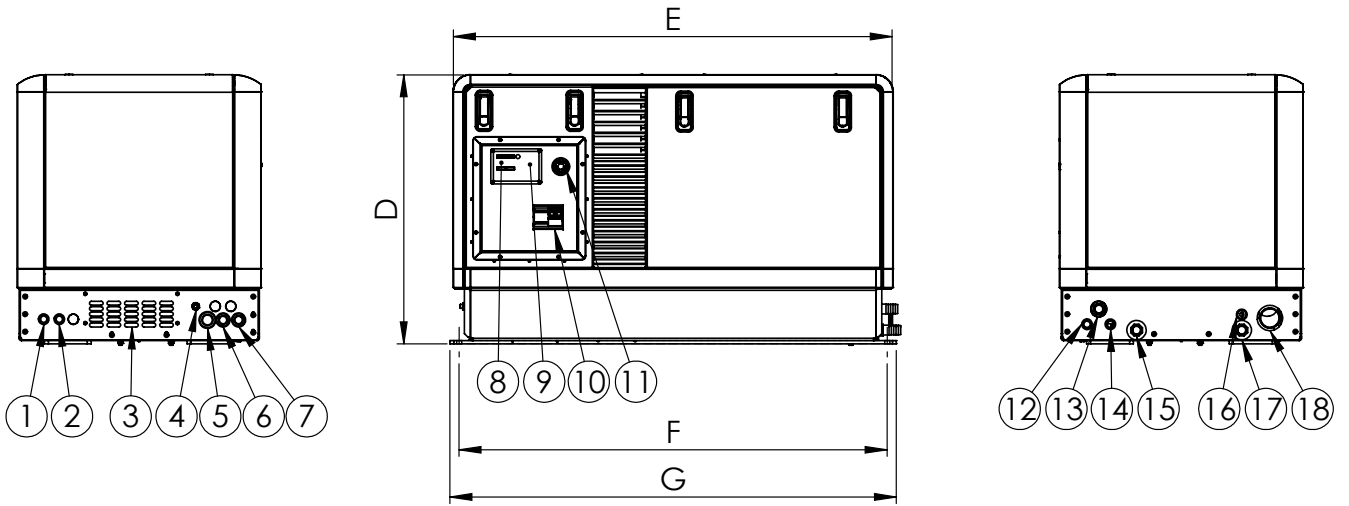

SQ-Pro 18

1. Battery "black" 35mm
2. Battery "red" 35mm
3. Air inlet
4. Earth lug M10
5. AC cable 3G 10mm (1phase)
AC cable 4G 6mm (2phase)
AC cable 5G 4mm (1phase)
6. Communication cable
7. Fuelpump powercable
8. Fuses
9. Local Control Panel
10. Circuit breaker
11. Emergency stop *option
12. To Syphon hose 3/4"
13. Fuel out 8mm
14. Fuel in 8mm
15. Water in hose 3/4"
16. From Syphon hose 3/4"
17. Exhaust
18. Drain
Marine: ø50 hose con.

19. Air filter
 20. Oil fill
 21. Accelerator
 22. Waterpump
 23. V-belt
 24. Oil filter
 25. Exhaust
 26. Dynamo
 27. Temperature sensor
 28. Lifting eye
 29. Coolant fill
 30. Manifold
 31. Starter motor
- A. 719 mm
B. 415 mm
C. 585 mm
D. 754 mm
E. 1210 mm
F. 1173 mm
G. 1220 mm

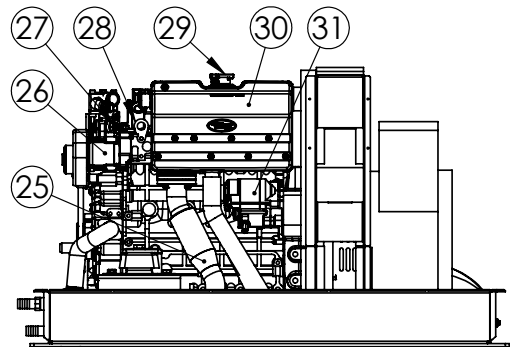
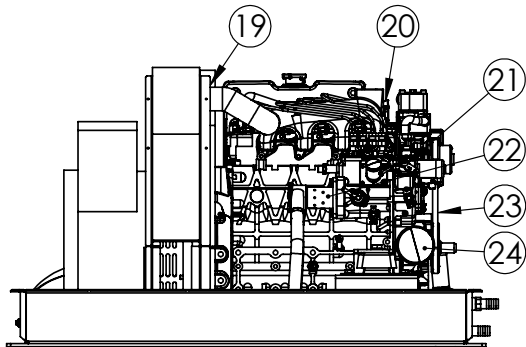
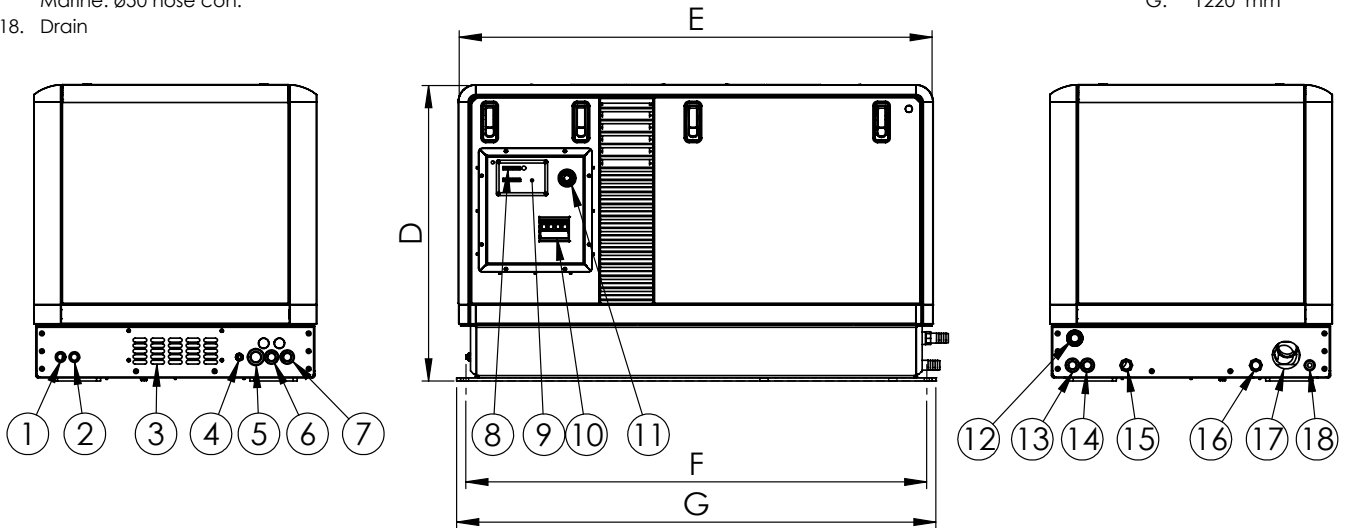
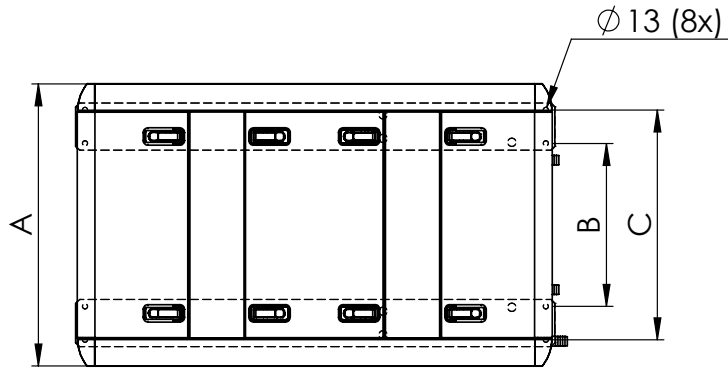

2.4.2 Generator control panel

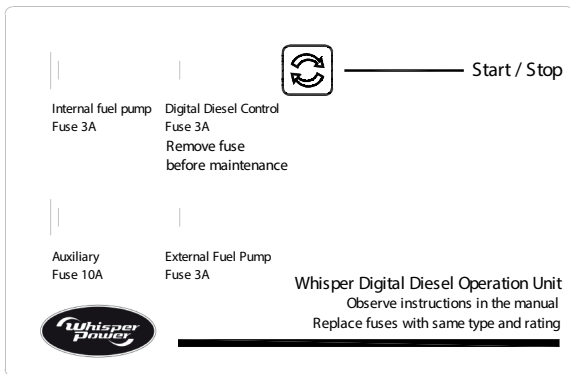

Fig. 8 Control panel.

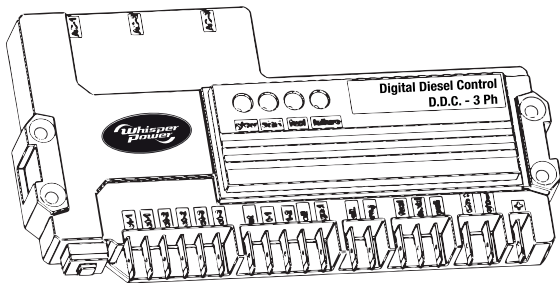

Fig. 9 Digital Diesel Control unit

2.4.3 Remote control panel



Fig. 10: Digital diesel remote control panel

- 1. Start button
- 2. Stop button
- 3. Select button
- 4. Set button
- 5. Failure lamp
- 6. Generator load indicator
- 7. Display

2.5 Technical Information

2.5.1 AC alternator

The synchronous alternator is directly coupled, one bearing, brushless, rotating field design, 12 wire, four pole (1500 RPM) and regulated by an Automatic Voltage regulator (AVR).

The exciter stator has a residual magnetism, which guarantees self-exciting of the generator on start-up (that thereby generates a residual voltage of about 10% nominal voltage).

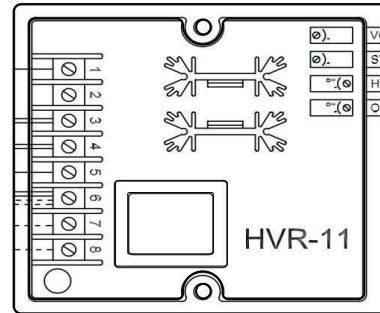

Fig 11: Automatic Voltage Regulator (AVR)

The AVR, powered by an auxiliary circuit on the main stator, acts on the exciter stator indirectly controlling the field generated by the main rotor by means of the sequence exciter rotor- diode bridge- main rotor.

The voltage regulator controls and keeps constant the average voltage of one phase. The voltage setting on the AVR can be adjusted with the help of a trimmer "VG" between 185 and 290 Volts. (See par. 5.3.1)

2.5.2 Engine

The M-SQ-Pro 15 and M-SQ-Pro 18 generating set are based on the Kubota V1505 and V2203 4 cylinder 4 stroke diesel engine. The engine is indirectly injected. The engine is water cooled and the cooling liquid is cooled by a heat exchanger and raw (sea) water. The heat exchanger and all other parts which are in direct contact with the raw (sea) water are made of seawater resistant material like naval brass and copper nickel.

The engine has been specially adapted for the WhisperPower application and is very different from the standard engine supplied for industrial applications!

2.5.3 Digital Diesel Control system

The standard electrical engine control system is 12 Volt negative earth, non-earth return (ungrounded) is available as optional. Check your identification data to determine which system is applied. The system is designed according to the "energize to run" system. The Digital Diesel Control is a very advanced microprocessor based full automatic system. Besides automatic start the system offers many monitoring options. See the separate Digital Diesel Control user's manual.

The microprocessor unit of the Digital Diesel Control is located next to the alternator.

2.5.4 Battery charger

On the engine is an alternator generating 40 Amp 12V. This current is rectified to charge the battery. The voltage is regulated at approx. 14.4V.

2.5.5 Alarms and shut down

In case of malfunctioning this will be indicated by the failure light, details will be shown on the display and the engine will be shut down. There are three functions guarded: oil pressure, oil temperature and exhaust temperature.

Exhaust temperature too high indicates the cooling water to be blocked.

All alarm switches are closed when no malfunction occurs. A contact is cut in the event of an alarm. This means that the generating set will not work when the alarm switches are broken or there is a loose wire. The system therefore is intrinsically safe. The panel will display details about the alarm.

2.5.6 Monitoring

Refer to the operating of the Digital Diesel Control

2.5.7 Control

The generating set can be operated by push buttons on the panel on the alternator or by the remote control. By pushing the START button the control system is activated and will start the engine automatically. Pushing the STOP button will stop the engine and the electrical system will be deactivated. Stopping the engine is executed by the solenoid that will shut off.

2.5.8 Remote control

All wiring connections from the remote control to the board are made by plug in connectors.

An intermediate communication cable is in the standard supply. If necessary an optional longer 8 wire communication cable can be connected if the standard length does not suit the required distance. Numerous remote control units can be put in parallel by using the connectors on the back of the units. (Refer to installation instructions)

The WhisperPower generating sets can be connected to a WhisperPower Touch panel. On this panel a complete WhisperPower system including the generator can be monitored and controlled. (Refer to the manual of the WhisperPower Touch panel for more information)

2.5.9 Hour counter

The remote control offers several timer functions that help to schedule maintenance.

2.5.10 Load indicator

On the remote control the load will be indicated on the display and by the LED-bar. The load is measured by current transformers on the alternator. All phases are monitored and overload of all phases or just one or two phases will provoke an alarm or even shut down when the alarm is ignored.

2.5.11 Fuel specification

The engine must only be used with diesel fuel oil which conforms to the standards for use in modern diesel engines. Fuel free from water and contaminants is of the utmost importance.

2.5.12 Oil information

1 Specification:

The oil must be suitable for oil changes as specified in the maintenance chapter. The engine must be run on heavy duty lubricating oil meeting the requirements of API class CF, CF-4, CH-4, CI-4 or CI-4 plus.



It is very important to use the correct oil specification. Very often local oil suppliers recommend a higher class, because they assume that a higher class is allowed. This is not the case. One should not follow these recommendations. Using the wrong specification will cause high oil consumption.

2 Oil viscosity:

We recommend a multigrade oil 10W40.

3 Oil capacity:

Excluding the oil filter the content of lubricating oil capacity is: 6,7 ltr. for SQ-Pro 15 / 7,6 ltr. for SQ-Pro 18. Note that the engine may contain some residual oil due to testing at the factory.

While filling, check the lubricating oil level by means of the engine oil dipstick. Do not overfill with lubricating oil as this may have a detrimental effect on engine performance.

4 Oil pressure

- Minimum at idle 98 kPa (1 kgf/cm²/14psi) (1 bar).
- At 2230 rpm ±300 kPa (3 kgf/cm²/45 psi) (3 bar).

2.5.13 Cooling liquid

The engine is cooled by cooling liquid. The capacity is:
4,0 ltr. for SQ-Pro 15 / 8,1 ltr. for SQ-Pro 18



Always use coolant which is compatible with aluminium components of the cooling system. Do not mix coolants with different kinds of chemical compound, as this may cause congelation of the coolant. In case of doubt refresh the content of the entire cooling system. Use only long-life type G12+ cooling liquid in order to minimize maintenance.

We recommend not using water but cooling liquid that is marketed for the use in combustion engines. Cooling liquid protects the engine against frost to minus 25° C. Also it protects the engine block against corrosion. One can fill the engine via the filling cap on the exhaust manifold. Fill up till the fluid is leveled with the indicator in the manifold (see fig 11). When the engine is on temperature the liquid will expand and the redundant liquid will be pressed into the expansion tank. This tank has to be filled up till the mark. When cooling liquid is not available clean fresh water could be used with an additive of anti-freeze. When using water with anti- freeze the right mixture has to be calculated according to the information of the supplier of the anti-freeze. When the cooling is based on keel cooling or radiator cooling the capacity of these coolers and piping has to be taken into account calculating the right mixture.

The cooling liquid in the engine is pressurised and has a

boiling point above 100° C. The temperature switch in the thermostat housing switches at 110° C. When keel cooling is applied the cooling system is not pressurised. There should be a special cap on the manifold without valves leaving the connection to the expansion tank open. See the special manual on keel cooling and radiator cooling.

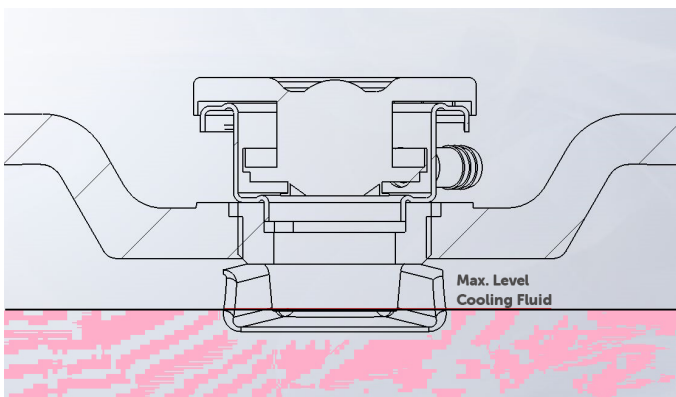

Fig.11 Komt hier een naam van dit afbeelding? of mag dit weg

2.5.14 Technical data

| | M-SQ Pro 15 | M-SQ Pro 18 |
|--------------------------------------|---|---|
| GENERAL | | |
| RPM | 1500-1800 rpm | 1500 |
| Alternator | 1 phase or 3 phase synchronous (air cooled) | |
| Engine | Kubota diesel, model V1505 BG | V2203 BG |
| Number of cylinders | 4 | 4 |
| Displacement | 1498 cm ³ | 2197 cm ³ |
| Bore X stroke | 78,0 x 78,4 mm | 87 x 92,4 mm |
| Combustion air consumption | 1,5 m ³ /min. | 1,52 m ³ /min |
| Continuous power 50 Hz | 12 kW electric power | 14 kW electric power |
| Cooling system | indirect cooling by raw water, 20-25 l/min. | 35 l/min. |
| Cooling water pump | PTO driven WhisperPower self-priming impeller pump | |
| Fuel lift pump engine | Mechanical pump, additional electrical pump available upon request | |
| Starting battery (optional) | 55 Ah 12V | 80 Ah 12V |
| Fuel consumption | 247 g/KWh | 235 g/KWh |
| Control | DDC or Deepsea | DDC or Deepsea |
| ELECTRICAL SPECIFICATIONS | | |
| Output voltage | 240V 50Hz / 60Hz , 1Phase 240/400V 50Hz/ 60Hz 3Phase | 240V 50Hz, 1Phase 254/440V 50Hz 3Phase |
| Continuous power kW at 25°C (77°F) | 11 kW, Stage V 12 kW, Non-Stage V | 14 kW, Stage V 16 kW, Non-Stage V |
| Voltage tolerance | ± 2% (balanced load) | |
| Frequency tolerance | ± 3% | |
| Alternator | Air cooled, brushless, 1Phase 3 wires, 3Phase 5 wires | |
| Voltage regulation: | AVR | AVR |
| MECHANICAL SPECIFICATIONS | | |
| Supply includes | Sound shield with steel base, mounted on rubber anti vibration mounts. (Genset without sound shield is optional) | |
| Dimensions in sound shield L x W x H | 1145 x 625 x 690 cm | 1220 x 719 x 754 cm |
| Dimensions without sound shield | 984 x 462 x 625 cm | 999 x 568 x 681 cm |
| Colour: | white / black | white / black |
| Weight with sound shield | 410 kg | 495 kg |
| Weight without sound shield | 370 kg | 455 kg |
| Max. Operation angle | 20 degrees | 20 degrees |
| Standard supplies | Remote panel (+15 m cable), fuel filter, fuel lift pump, user and installation manuals | |
| Optional | Installation kits, non-earth return (ungrounded), spare part kits, | |

2.5.15 WIRING CODES AND COLORS

WIRING COLOURS W-SQ-PRO 15 1 & 3PHASE - MOBILE

| Description | Cable number | Color | Cross section | 3 phase only |
|---------------------------------------|--------------|------------|---------------------|--------------|
| Starter motor > Alternator | 1 | Red | 10 mm ² | |
| Battery > starter motor | 1 | Red | 35 mm ² | |
| Starter motor > DDC | 1 | Red | 36 mm ² | |
| Starter motor > LCP | 1 | Black | 1,5 mm ² | |
| Generator EXC- > AVR M1 | 3 | Black | 1,5 mm ² | |
| Generator EXC+ > AVR M3 | 4 | Black | 1,5 mm ² | |
| AVR M3 > AVR M4 | 5 | Black | 1,5 mm ² | |
| Generator WT > AVR WT | 6 | Black | 1,5 mm ² | |
| Generator YL > AVR M5 | 7 | Black | 1,5 mm ² | |
| Generator BK > AVR M6 | 8 | Black | 1,5 mm ² | |
| Generator GN > AVR M6 | 9 | Black | 1,5 mm ² | |
| Measuring Coil T1:S1> DDC ct1 | 10 | Red | 2,5 mm ² | |
| Measuring Coil T1:S2> DDC ct1 | 11 | Black | 2,5 mm ² | |
| Measuring Coil T2:S1> DDC ct2 | 12 | Red | 2,5 mm ² | 3 phase only |
| Measuring Coil T2:S2> DDC ct2 | 13 | Black | 2,5 mm ² | |
| Measuring Coil T3:S1> DDC ct3 | 14 | Red | 2,5 mm ² | |
| Measuring Coil T3:S2> DDC ct3 | 15 | Black | 2,5 mm ² | |
| Fuel Pump + > LCP | 17 | Black | 1,5 mm ² | |
| Generator R > DDC hold | 18 | White | 1,5 mm ² | Gen. D+ |
| DDC hold > Bridge Rectifier | 18 | Green | 1,5 mm ² | |
| Bridge Rectifier > Fuel Solenoid hold | 18 | Green | 1,5 mm ² | |
| Bridge Rectifier > Fuel Solenoid pull | 19 | Pink | 2,5 mm ² | |
| DDC pull > Bridge Rectifier- | 19 | Pink | 2,5 mm ² | |
| Fuel Pump- > LCP | 20 | Black | 1,5 mm ² | |
| DDC gnd > LCP | 20 | Black | 1,5 mm ² | |
| Ground > LCP | 20 | Black | 1,5 mm ² | |
| LCP > Temp Switch Exhaust | 20 | Black | 1,5 mm ² | |
| LCP > Temp Switch Coolant | 20 | Black | 1,5 mm ² | |
| Ground > battery | 20 | Black | 35 mm ² | |
| DDC start > Starter motor- | 21 | Black | 2,5 mm ² | |
| Alternator L > DDC alt | 23 | Orange | 1,5 mm ² | |
| DDC gl > Glow Plugs | 24 | Black | 6 mm ² | |
| DDC reg > LCP | 37 | Black | 1,5 mm ² | |
| DDC start > LCP | 38 | Black | 1,5 mm ² | |
| DDC fuel > LCP | 39 | Black | 1,5 mm ² | |
| Temp Switch Exhaust > DDC t2 | 46 | Blue/Green | 1,5 mm ² | |
| Temp Switch Coolant > DDC t1 | 47 | Blue | 1,5 mm ² | |
| Oil Pressure Switch > DDC oil | 48 | Violet | 1,5 mm ² | |
| LCP j7 > LCP j18 | 49 | Black | 1,5 mm ² | |

| Description | Cable number | Color | Cross section | 3 phase only | |
|---|--------------|--------------|---------------------|--------------|--|
| Generator L1-1 > Circuit Breaker-1 | L1-1 | Brown | 16 mm ² | | |
| Generator L1-1 > DDC ac1 | L1-1 | Brown | 1,5 mm ² | | |
| Generator N-1 > Contact-2 | N-1 | Blue | 16 mm ² | | |
| DDC ac1 > Generator-N | N-1 | Blue | 1,5 mm ² | | |
| Contact-2 > Circuit Breaker-3 | N-1 | Blue | 16 mm ² | | |
| Contact-3 > Generator pe | Pe-1 | Green/Yellow | 16 mm ² | | |
| Generator U > Circuit Breaker-1 | L1-1 | Brown | 6 mm ² | 3 phase only | |
| Generator U > DDC ac1 | L1-1 | Brown | 1,5 mm ² | | |
| Generator V > DDC ac2 | L2-1 | Black | 1,5 mm ² | | |
| Generator V > Circuit Breaker-3 | L2-1 | Black | 6 mm ² | | |
| Generator W > Circuit Breaker-5 | L3-1 | Grey | 6 mm ² | | |
| Generator W > DDC ac3 | L3-1 | Grey | 1,5 mm ² | | |
| Generator N > DDC ac3 | N-1 | Blue | 1,5 mm ² | | |
| Generator N > Contact-4 | N-1 | Blue | 6 mm ² | | |
| Contact-4 > Circuit Breaker-7 | N-1 | Blue | 6 mm ² | | |
| Generator N > DDC ac1 | N-1 | Blue | 1,5 mm ² | | |
| Generator N > DDC ac2 | N-1 | Blue | 1,5 mm ² | | |
| Contact-5 > Generator pe | PE-1 | Green/Yellow | 6 mm ² | | |
| Starter Motor > Alternator + | 1 | Red | 10 mm ² | | |
| Battery > Starter Motor + | 1 | Red | 35 mm ² | | |
| Starter Motor + > DDC + | 1 | Red | 6 mm ² | | |
| Starter Motor + > LCP j4 | 1 | Red | 2,5 mm ² | | |
| Generator EXC- > AVR m1 | 3 | Black | 1,5 mm ² | | |
| Generator EXC + > AVR m3 | 4 | Black | 1,5 mm ² | | |
| AVR m3 > AVR m4 | 5 | Black | 1,5 mm ² | | |
| Generator wt > AVR m4 | 6 | Black | 1,5 mm ² | | |
| Generator yl > AVR m5 | 7 | Black | 1,5 mm ² | | |
| Generator bk > AVR m6 | 8 | Black | 1,5 mm ² | | |
| Generator gn > AVR m6 | 9 | Black | 1,5 mm ² | | |
| Measuring Coil T1:S1 > DDC ct1 | 10 | Red | 2,5 mm ² | 3 phase only | |
| Measuring Coil T1:S2 > DDC ct1 | 11 | Black | 2,5 mm ² | | |
| Measuring Coil T2:S1 > DDC ct2 | 12 | Red | 2,5 mm ² | | |
| Measuring Coil T2:S2 > DDC ct1 | 13 | Black | 2,5 mm ² | | |
| Measuring Coil T3:S1 > DDC ct3 | 14 | Red | 2,5 mm ² | | |
| Measuring Coil T3:S2 > DDC ct3 | 15 | Black | 2,5 mm ² | | |
| Fuel Pump + > LCP j20 | 17 | Black | 1,5 mm ² | | |
| Alternator R > Vandal resistant Switch-no | 18 | Black | 1 mm ² | Gen. D+ | |
| Alternator R > DDC hold | 18 | White | 1,5 mm ² | | |
| DDC hold > ECU V2203-15 | 18 | White | 1 mm ² | | |
| DDC hold > ECU V2203-16 | 18 | White | 1 mm ² | | |
| DDC ground > LCP j12 | 20 | Black | 1,5 mm ² | | |

| Description | Cable number | Color | Cross section | 3 phase only |
|--|--------------|--------------|---------------------|--------------|
| Alternator R > DDC hold | 18 | White | 1,5 mm ² | |
| DDC hold > ECU V2203-15 | 18 | White | 1 mm ² | |
| DDC hold > ECU V2203-16 | 18 | White | 1 mm ² | |
| DDC ground > LCP j12 | 20 | Black | 1,5 mm ² | |
| Ground > LCP j17 | 20 | Black | 4 mm ² | |
| ECU V2203-1 > LCP j11 | 20 | Black | 1 mm ² | |
| ECU V2203-19 > LCP j16 | 20 | Black | 1 mm ² | |
| LCP > Temp Switch Exhaust | 20 | Blue/Pink | 1 mm ² | Marine Only |
| LCP > Pickup-1 | 20 | Black | 1 mm ² | |
| LCP > Temp Switch Coolant | 20 | Brown/Black | 1 mm ² | |
| LCP > Coolant Temp Sensor-2 | 20 | Red/Green | 1 mm ² | |
| Fuel Pump- > LCP j10 | 20 | Black | 1,5 mm ² | |
| Ground > Battery- | 20 | Black | 35 mm ² | |
| DDC start > Starter Motor s | 21 | Yellow | 2,5 mm ² | |
| Alternator I > DDC alt | 23 | Orange | 1,5 mm ² | |
| DDC alt > ECU V2203-26 | 23 | Black | 1 mm ² | |
| DDC gl > Glow Plugs | 24 | Brown | 6 mm ² | |
| ECU V2203-34 > Governer-2 | 32 | Yellow | 1 mm ² | |
| ECU V2203-18 > Governer-1 | 33 | Grey | 1 mm ² | |
| Coolant Temp Sensor-1 > ECU V2203-13 | 34 | Red | 1 mm ² | |
| Pickup-2 > ECU V2203-17 | 35 | Green | 1 mm ² | |
| Pickup-3 > ECU V2203-20 | 36 | Pink | 1 mm ² | |
| DDC reg > LCP j19 | 37 | Black | 1,5 mm ² | |
| DDC st > LCP j22 | 38 | Red/Green | 1 mm ² | |
| DDC fuel > LCP j21 | 39 | Grey | 1,5 mm ² | |
| Vandal resistant Switch + > LCP j5 | 41 | Black | 1 mm ² | |
| LCP j5 > Vandal resistant Switch-C | 41 | Black | 1 mm ² | |
| Vandal resistant Switch- > ECU V2203-9 | 45 | Black | 1 mm ² | |
| Temp Switch Exhaust > DDC t-2 | 46 | Blue/Green | 1 mm ² | |
| Temp Switch Coolant > DDC t-1 | 47 | Blue | 1 mm ² | |
| Oil Pressure Switch > DDC oil | 48 | Violet | 1 mm ² | |
| LCP-j7 > LCP-j18 | 49 | Black | 1,5 mm ² | |
| Generator L > DDC ac1 | L1-1 | Brown | 1,5 mm ² | 3 phase only |
| Generator L > Circuit Breaker-1 | L1-1 | Brown | 16 mm ² | |
| Generator N > Contact-3 | N-1 | Blue | 16 mm ² | |
| Generator N > DDC ac1 | N-1 | Blue | 1,5 mm ² | |
| Contact-3 > Circuit Breaker-3 | N-1 | Blue | 16 mm ² | |
| Contact-4 > Generator PE | PE-1 | Green/Yellow | 16 mm ² | |

DDC = Digital Diesel Control Unit
 LCP = Local Control Panel
 ECU = Engine Control Unit (Kubota)
 AVR = Electronic Regulation Generator

2.5.16 Lay out control wiring M-SQ PRO 15 1-Phase Kubota

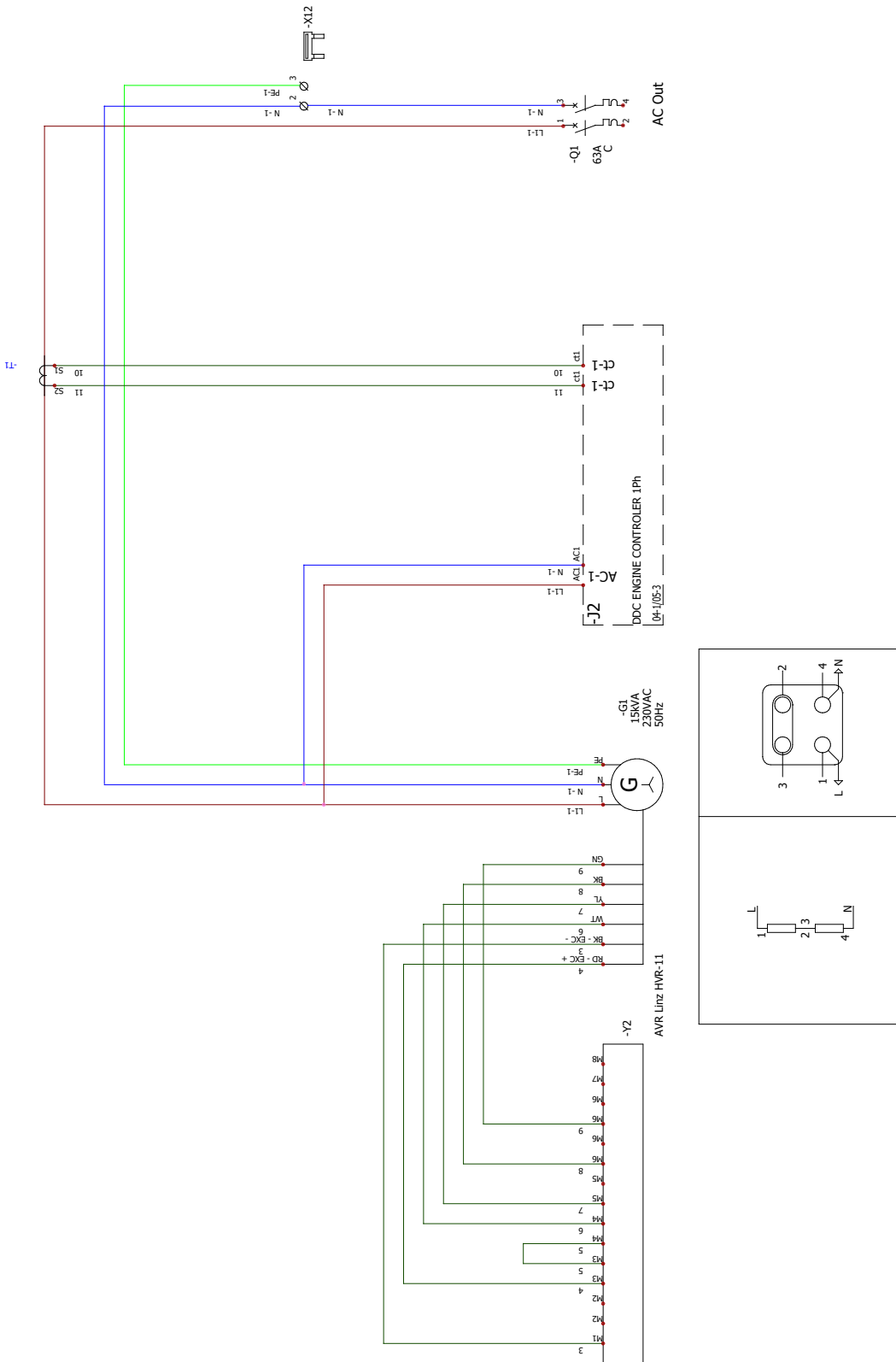

2.5.17 Lay out control wiring M-SQ PRO 15 1-Phase Kubota

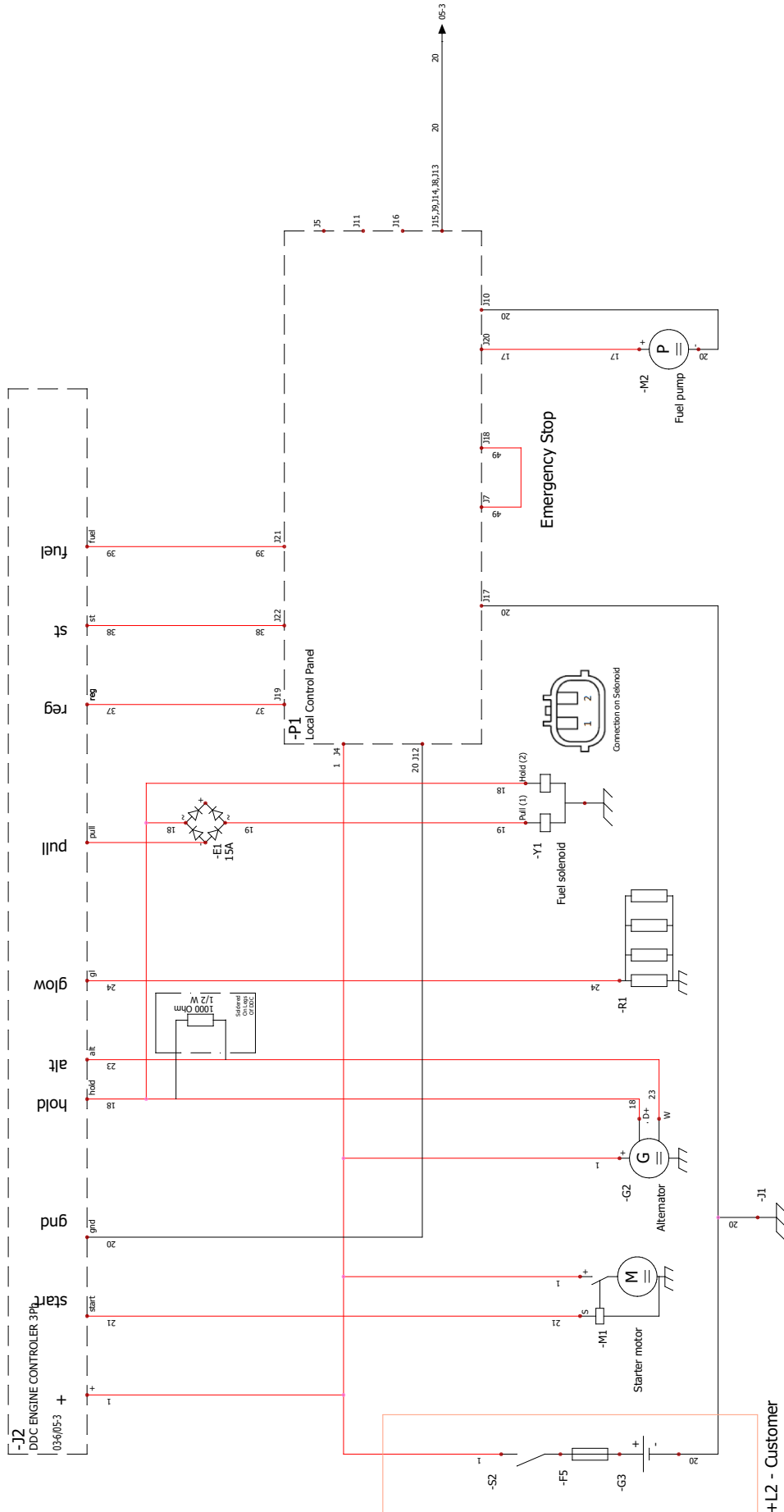

2.5.18 Lay out control wiring M-SQ PRO 15 1-Phase Kubota

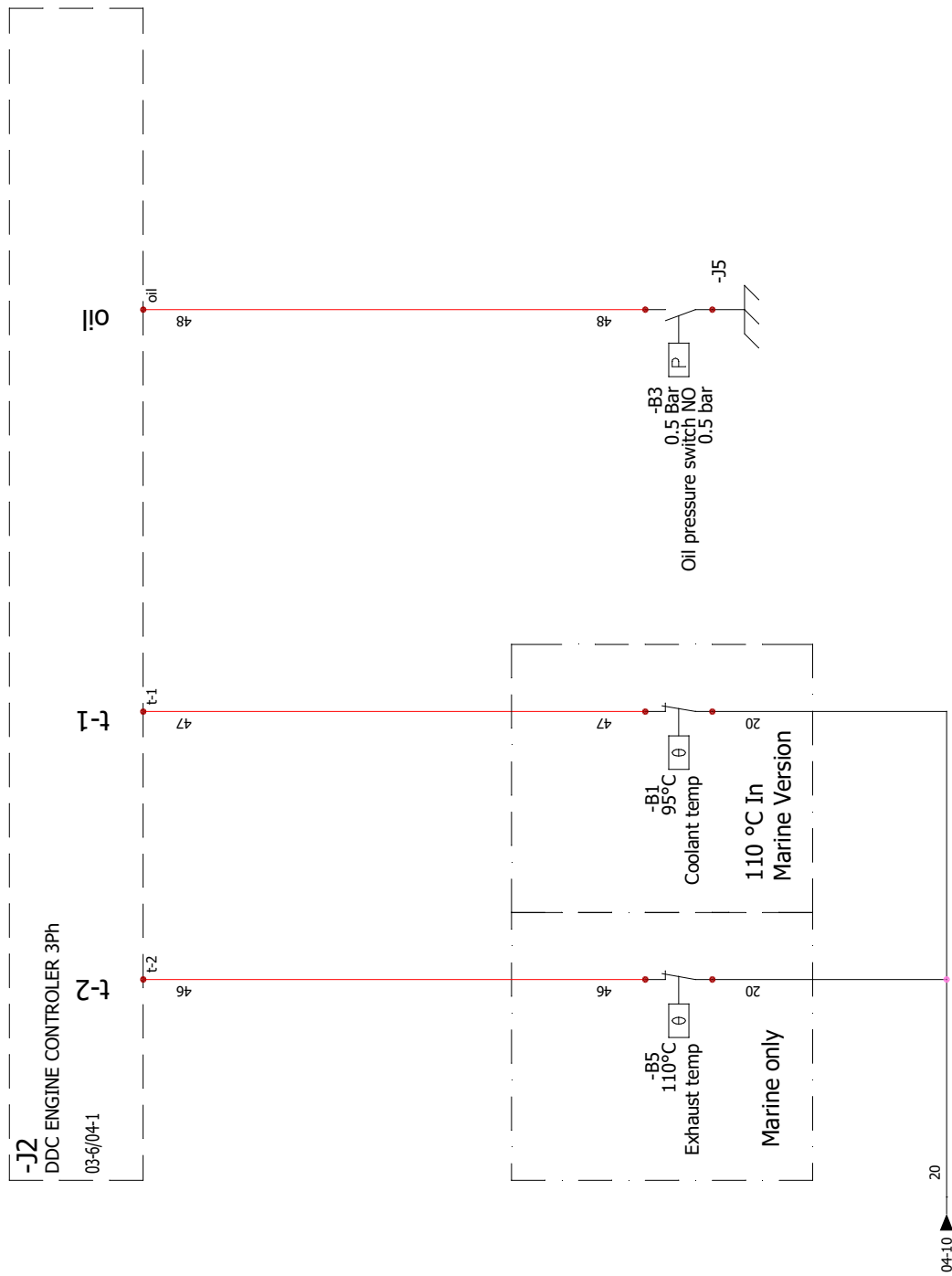
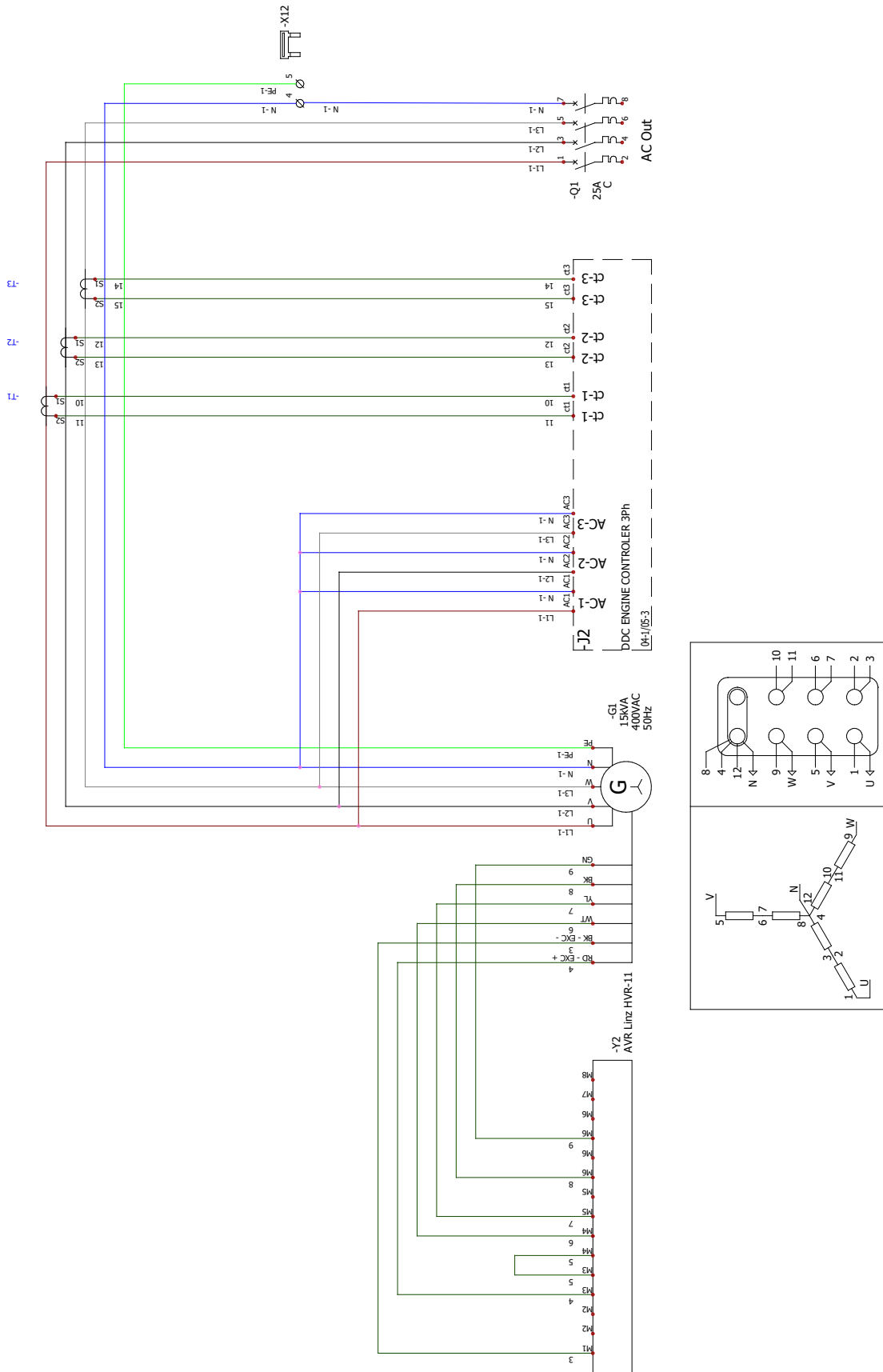

Fig. 14: Terminal modes

2.5.19 Lay out control wiring M-SQ PRO 15 3-Phase Kubota



2.5.20 Lay out control wiring M-SQ PRO 15 3-Phase Kubota

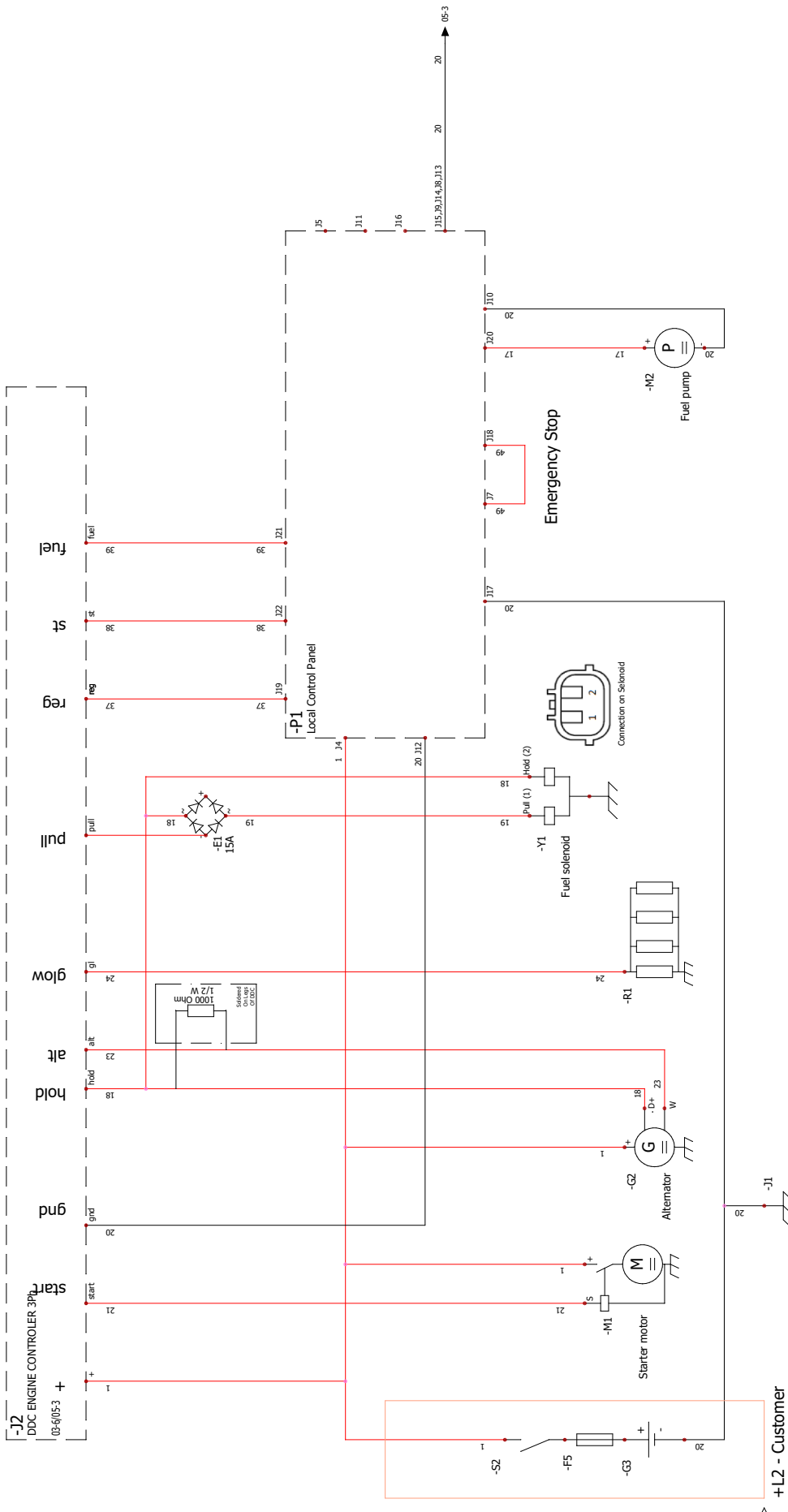
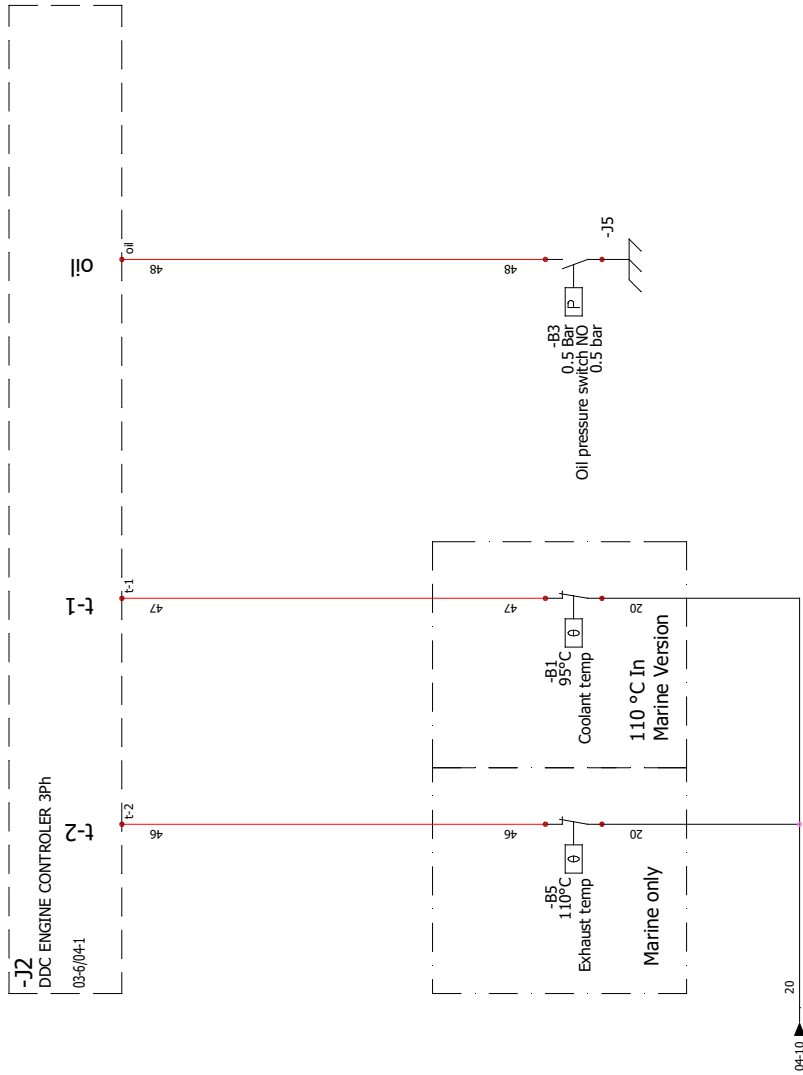
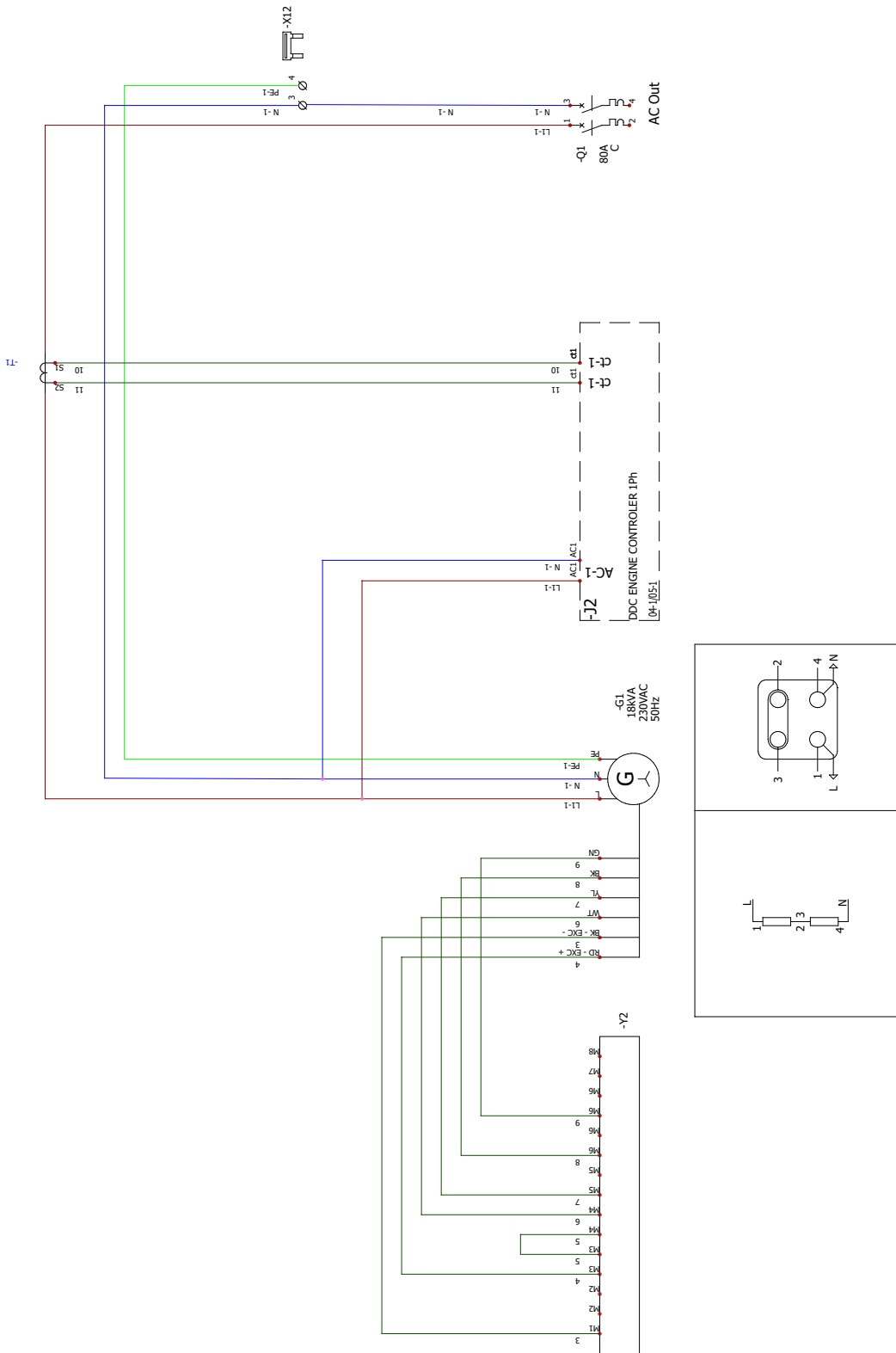

Fig. 15: Generator diagram 3 phase with AVR 230V – 400V 50Hz with AVR

2.5.21 Lay out control wiring M-SQ PRO 15 3-Phase Kubota



2.5.22 Lay out control wiring M-SQ PRO 18 1-Phase Kubota



2.5.23 Lay out control wiring M-SQ PRO 18 1-Phase Kubota

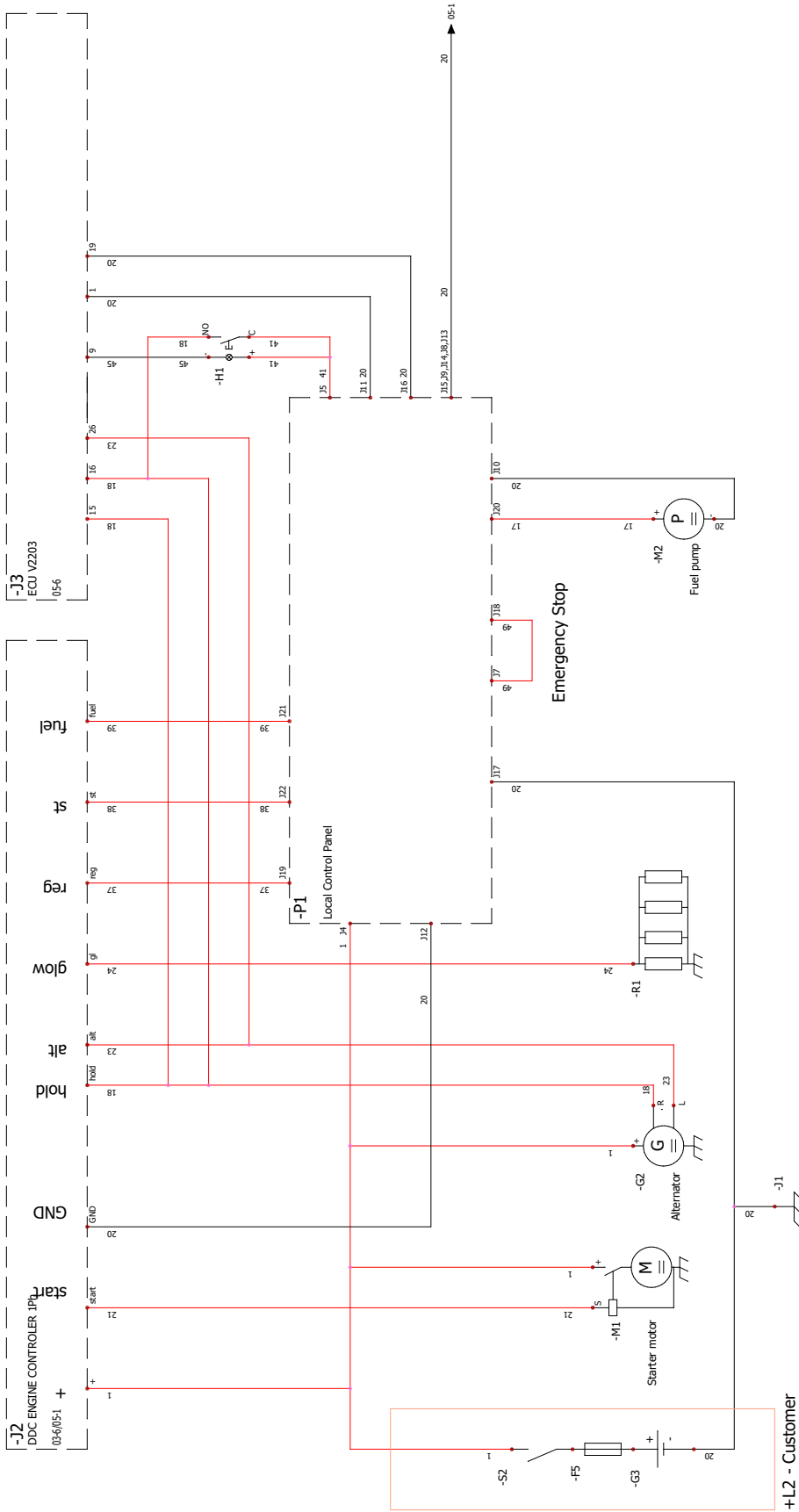

2.5.24 Lay out control wiring M-SQ PRO 18 1-Phase Kubota

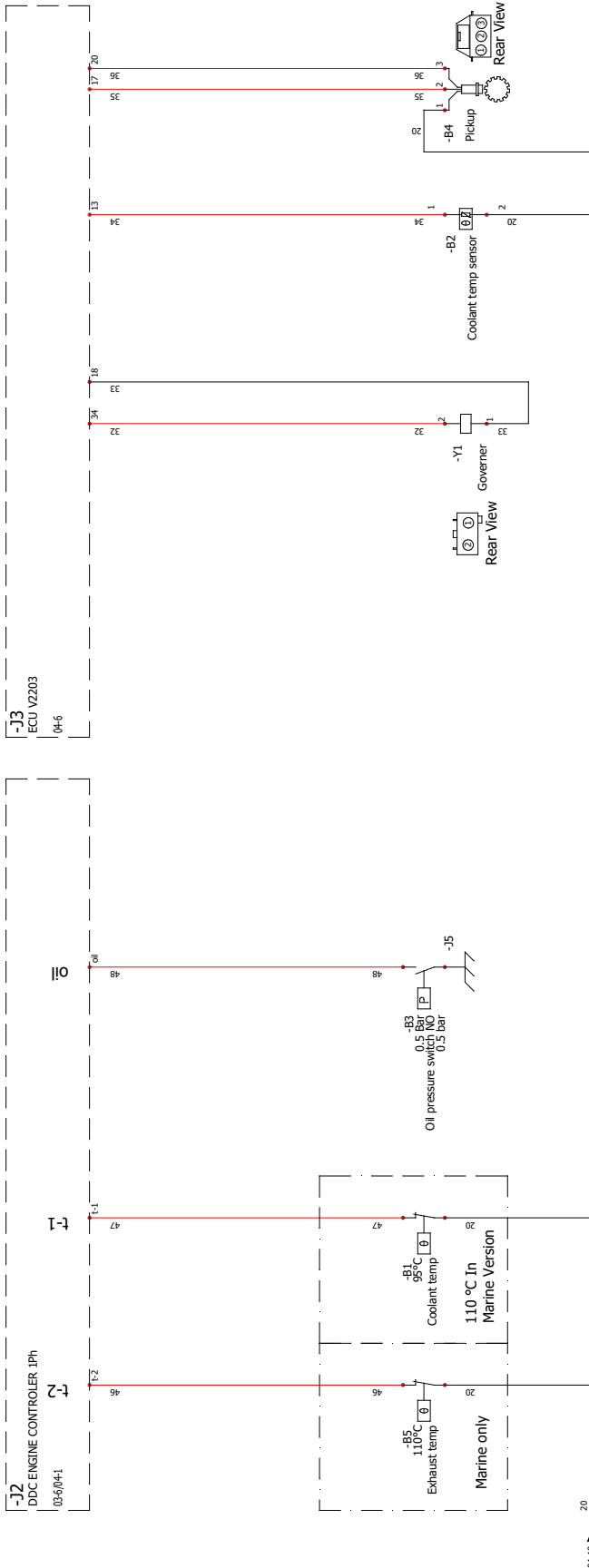

2.5.25 Lay out control wiring M-SQ PRO 18 3-Phase Kubota

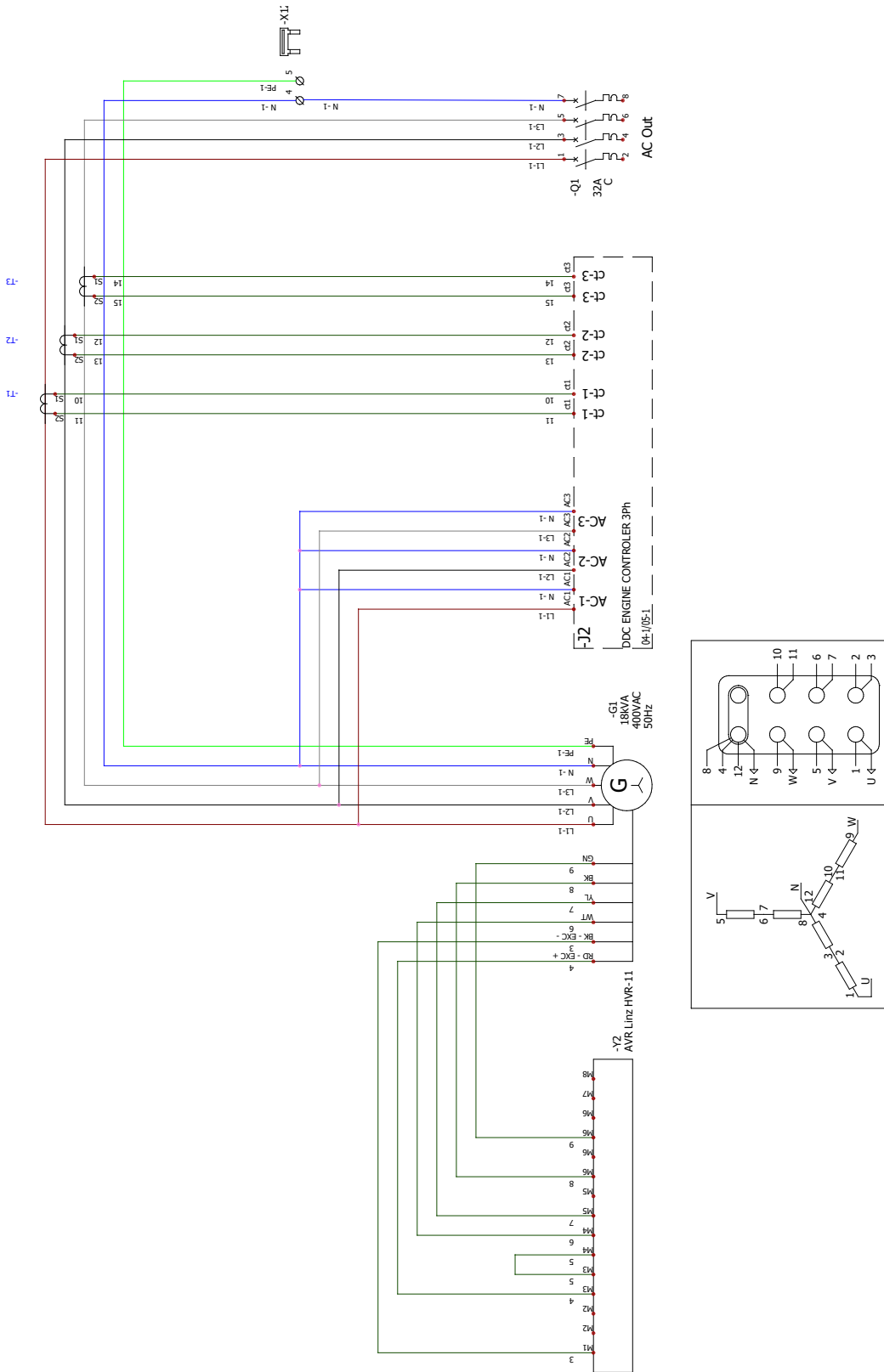

2.5.26 Lay out control wiring M-SQ PRO 18 3-Phase Kubota

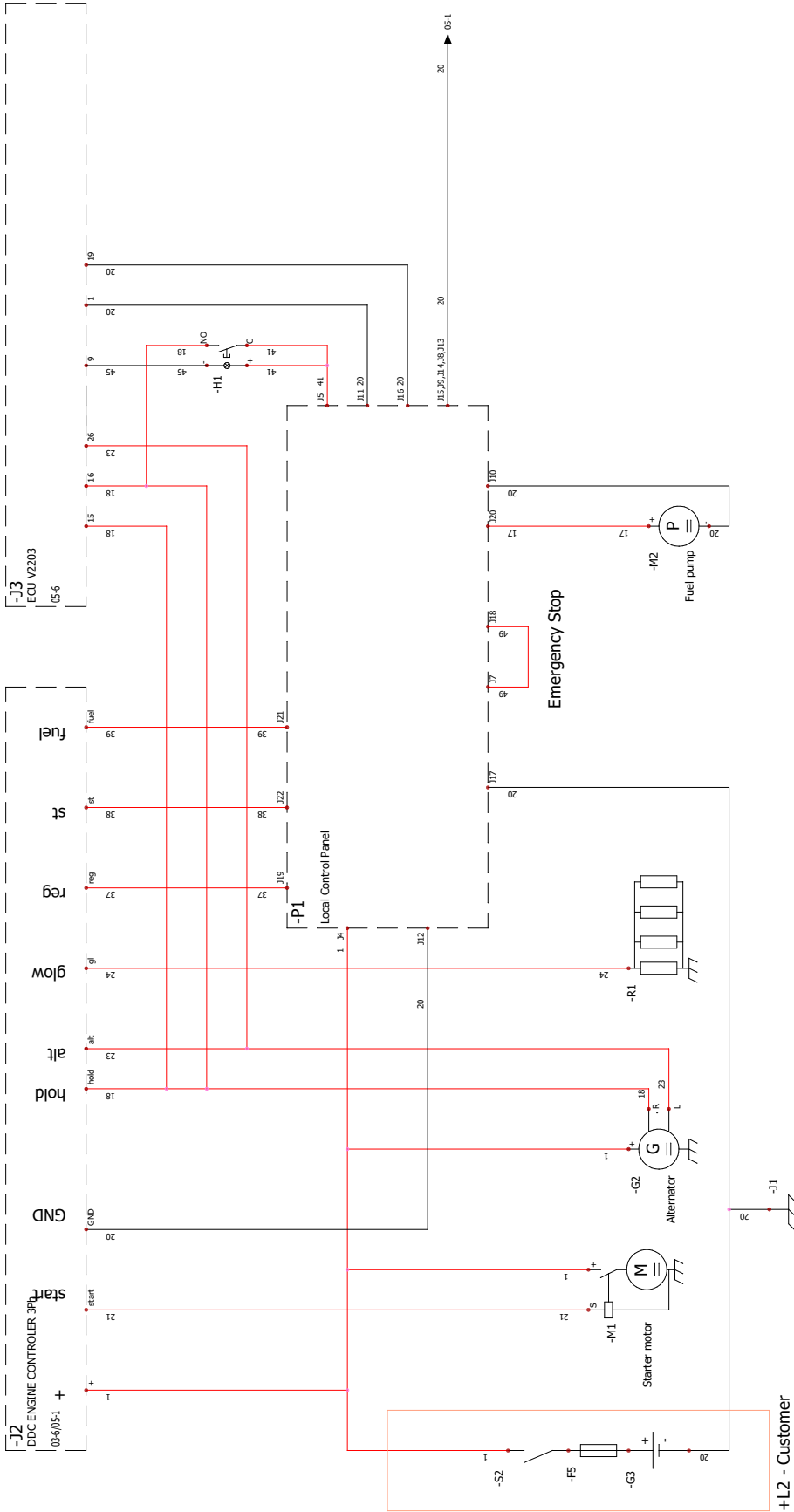

2.5.27 Lay out control wiring M-SQ PRO 18 3-Phase Kubota

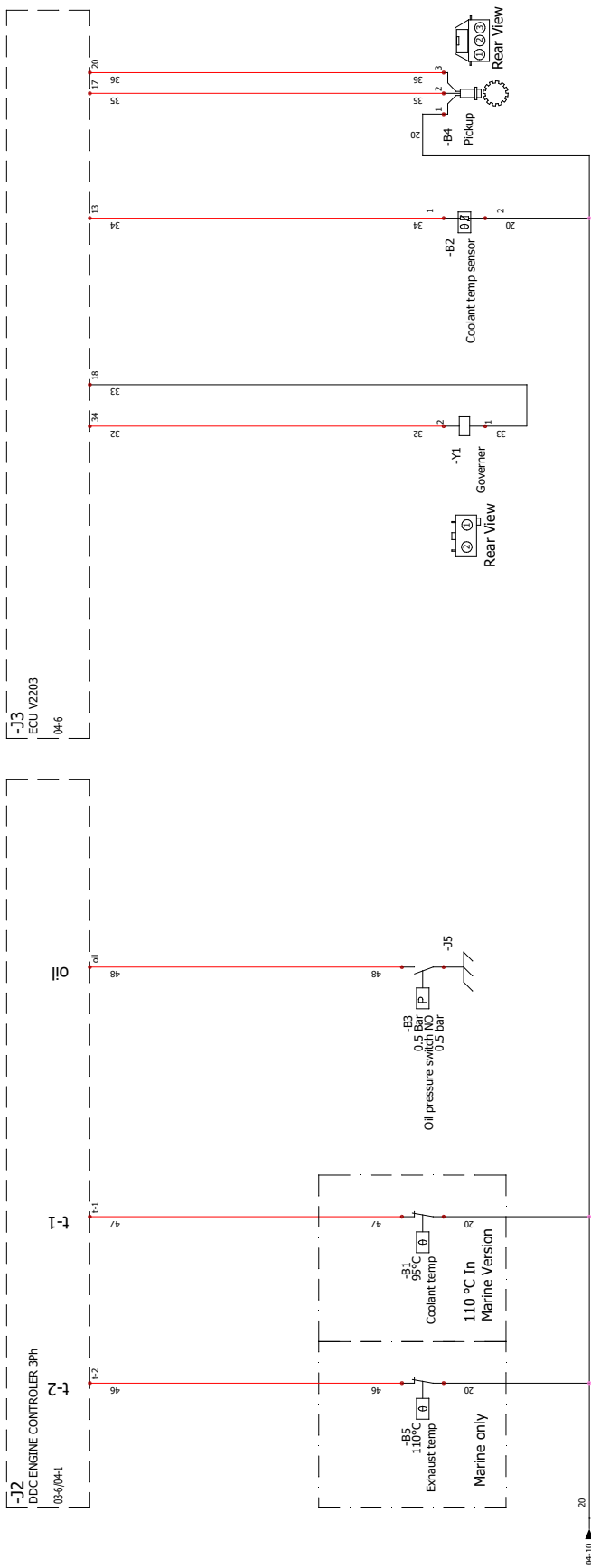

3 OPERATION

3.1 General

The generating set is operational after full installation and filling up with: fuel, engine lubricating oil and cooling liquid, filling the starter battery with acid (WhisperPower batteries do not need to be filled up and are sealed), connecting the remote control panel.

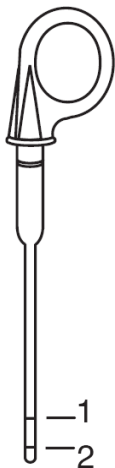

- 1 Max. oil level;
2 Min. oil level.

Fig. 17: Engine oil dipstick markings

3.2 Operating Instructions

3.2.1 Summarized operating instructions (daily use)

Routine “pre-start” checks:

1. Check oil level.
2. Water inlet (all valves open).
3. Power source selector switch (off/shore power/generator power). Switch to power source switch “OFF”, or switch off all consumers in the usual way. If a WhisperPower Switch is installed, this is operating automatically.
4. Switch on battery switch (when installed).
5. Fuel valve: open.

Starting:

Push the start button to initiate the full automatic starting procedure. You can monitor the procedure on the display.

In operation checks:

1. Check for abnormal noise or vibration
2. Check the voltage
3. Check sea water flow at exhaust outlet
4. Power source selector switch (off/shore power/generator power). Switch to power source generator. If a WhisperPower Switch is installed, this is operating automatically.
5. Before loading the generating set up to maximum, have it run warm. Continuous load should be restricted to 70 % of maximum load.

Stopping generator:

1. Switch off all electrical devices (consumers). If the generating set has been running under full load for a longer period, do not shut it down abruptly. Reduce the electrical load to about 30% of the rated load and let it run for approx. 5 minutes.
2. Press the STOP button.
3. Close the inlet sea water cock.
4. Switch to another 230V/400V power source, if available. If a WhisperPower Switch is installed, this is done automatically.

3.2.2 Extended operating instructions

Check when starting the first time or after a longer period of rest:

1. If there is any damage caused by transport or installation.
2. Check if installation conforms to the installation instructions.
3. Ensure the generating set is free to turn without obstruction.
4. Check all hoses and hose connections for leaks.
5. Check all cables and cable end terminal connections.
6. Check the engine and generator mounting bolts.

Routine “pre-start” checks:

1. Check engine oil level.
2. The generator switches off in the event of insufficient oil-pressure. Even when the oil level is too low the oil pressure can be high enough. Do not run the generator with the oil below the lowest mark in the, because a smaller volume of oil will become contaminated considerably quicker than a larger volume. Therefore we recommend daily oil-checks.
3. Check oil level prior to starting the engine or at least 5 minutes after the engine has stopped.
4. Check sea water cocks. Do not forget the valve of the water outlet in case of a water/exhaust gas separator.
5. Check the water strainer.
6. Check for leakages.
7. Regularly check the siphon vent in the cooling water supply.
8. If no WhisperPower Switch is used: Switch main Power Source Selector switch to “OFF” or switch off all devices.
9. Switch on the battery switch.

Starting the generator:

By pushing the start button briefly the electric system is activated and the starting procedure will begin. (By pushing the stop button the system is deactivated) The first time starting up or after running out of fuel it could be necessary to prime the fuel system. (See bleeding fuel system instructions in the maintenance chapter).

A restart protection prevents starting the engine when it is already running, which could cause damage.



In the event of starting problems (numerous attempts are made), close the sea-water inlet cock while cranking to prevent the outlet system and engine to fill up with water.

During the starting process, the cooling water pump is driven with the engine. The cooling water is discharged to the exhaust outlet, because the engine does not run, the exhaust pressure is not high enough to expel this water.

Open the valve immediately when the engine starts in order to prevent damaging the impeller.

Water in the cylinders will cause serious damage to the engine. For instance; a bent piston rod or a cracked cylinder head. In fact water in the cylinder is the main cause for engine damage in pleasure craft.

Checks once the generator is in operation:

1. Check for abnormal noise or vibration.
2. Check the voltage.
3. Check coolant flow.

Always check immediately after starting the generator if cooling water flows at the exhaust outlet. If this is not the case, check the cooling water pump. After having become acquainted with the generator you will be able to recognise the coolant flowing through the system by listening for the noise of the water which is expelled.



Be aware that especially in harbours the coolant water inlet can easily be blocked by floating objects.

4. Power source selector switch (off/shore power/generator power). Switch to power source generator. If a WhisperPower Switch is installed, this operates automatically.

Before loading the generating set up to maximum, have it run warm. The first 50 hours of running the continuous load should be restricted to 70 % of maximum load. Running for long periods at no load or light load in the first

50 hours can cause cylinder glazing and high oil consumption.

Engine load during longer operation:

Please ensure that the generating set is not overloaded. Overloading occurs when the electrical load (demand) is so high that the generator cannot be turned around properly by the diesel engine. Overloading causes the engine to run rough, while using oil and excessive fuel and producing soot by the exhaust. The engine can even stop.

The generator should therefore only be loaded at the maximum rated power for short periods (2-3 hours) only! The high peak current is meant for the ability to start electrical devices that need a high current for starting especially electric motors and compressors (from a still stand state).

In order to prolong the generating set's life expectancy, the nominal electrical demand on the system should be about 70% or the rated generating set's maximum load. Please note this when switching on your electrical devices!

Nevertheless, the Whisper is designed so as not to overheat, even under extreme conditions.

Do not run the generator for very long periods at no load or at very low load. When this is necessary do load the generator at least one hour in 10 hours for minimum 70%. Long term running at too low load will cause the exhaust to be choked by carbon.



Never remove the battery while the engine is running or any electrical cable while the battery is connected in the circuit. Only disconnect the battery with the engine stopped and all switches in "OFF" position.

Stopping the generating set:

1. Avoid stopping of the generator abruptly after a long period of operation at high load! Doing so, you avoid unnecessary thermal load to your generating set!
Act as follows:
Prior to switching off the generating set, decrease the generator load (i.e. turn off most electrical users) and let the generator run at low load for approx. 5 minutes to allow the engine to get properly cool (the influent sea water must flow through the system in order to cool the engine).
If the generator is operating in a hot environment and you do not act as given above, the excessive heat in the engine can trip the "high temp" alarms. In that case, a restart of the engine is not possible for some time. It is also recommended to switch off electrical users prior to stopping the generator because of the voltage drop that occurs as the engine comes to a halt. Such voltage drops may cause damage to electric motors, compressors (in refrigerators or air conditioners etc.).
2. Press the STOP button.
3. Close the inlet sea water cock.
4. Switch to another 230V/400V power source, if available. If a WhisperPower Switch is installed, this is done automatically



If the engine is not running and 'failure' and 'charging' LED is blinking, reset by stop button, otherwise it will drain the start battery.

4 MAINTENANCE

4.1 Alternator

The alternator does not require any maintenance. Periodic inspection and cleaning is recommended, depending on environmental conditions. However when the alternator has been idle for a long period attention to winding condition is recommended.

The condition of windings can be assessed by measurement of insulation resistance to earth. (See 5.3.5 Meggering)

The alternator bearing is greased for life and is therefore not regreasable.

4.2 Engine

4.2.1 Preliminary instructions

All regular maintenance can be carried out when the enclosure is open. When oil and dirt has gathered in the enclosure measures have to be taken to avoid spilling oil and polluting the environment.

The first service on the engine should be carried out after 50 hours of its life and after a major overhaul. In the first 50 hours the engine should receive special attention:

Long periods of light or no load running in the first 50 hours may lead to cylinder glazing and high oil consumption.



For the same reason it is of the greatest importance to use the right oil specification.

The first time starting up or after running out of fuel it could be necessary to prime the fuel system.

4.2.2 Bleeding fuel lines

Ensure there is sufficient fuel. The Whispers are self-bleeding. To check the well-functioning release the bleed screw on the high pressure fuel pump. Turn loose the cap of the fuel lift pump, and move the piston up and down to prime the system. Retighten the bleed screw when no further air bubbles are expelled. Retighten the cap when ready.

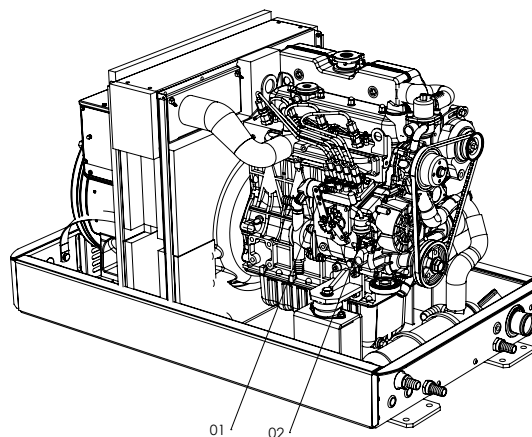

- 01 Injection pump air bleeding screw
- 02 Hand operated fuel lift pump

Fig. 18: Bleeding fuel lines

4.2.3 Valve clearance

When the engine is in cold condition both valves (inlet and outlet) should have a clearance of 0.25 mm. The adjustment has to be done at TDC (see 5.4.2).

4.2.4 Replacing fuel filter

Filter change depends on contamination of the fuel, but should be done however, at least every 300 running hours. A clogged filter results in a lack of output of the generating set.

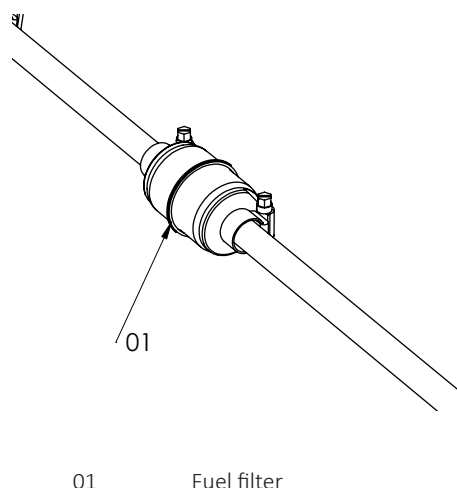

- 01 Fuel filter

Fig. 19: Location fuel filter cartridge

4.2.5 Replacing oil filter

Replacement has to be executed according to the schedule in this manual. Drain the oil using the sump pump and put some tissues under the filter.

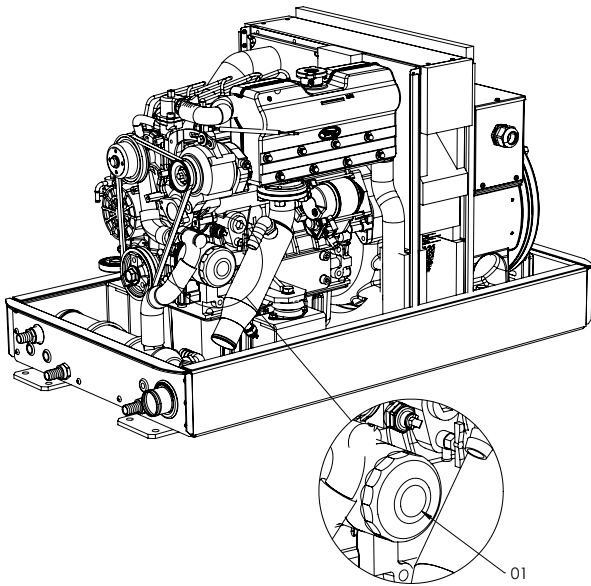

01 Engine oil filter

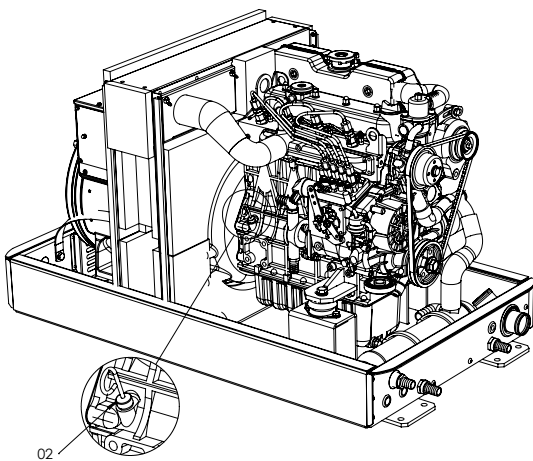

02 Engine oil dipstick

Fig. 20: Location engine oil filter and dipstick

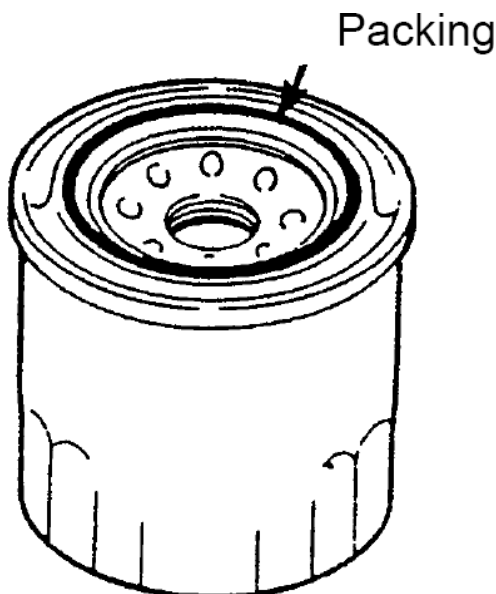

Fig. 21: Location rubber packing-ring oil filter

A smear of oil has to be put on the seal of the filter before fitting the filter. The filter should be fastened manually: when the rubber touches the metal turn 3/4 further.

4.2.6 Tensioning V-belt

The alternator bracket allows for readjust of the V-belt. Deflections should be 13 mm (see fig. 22)

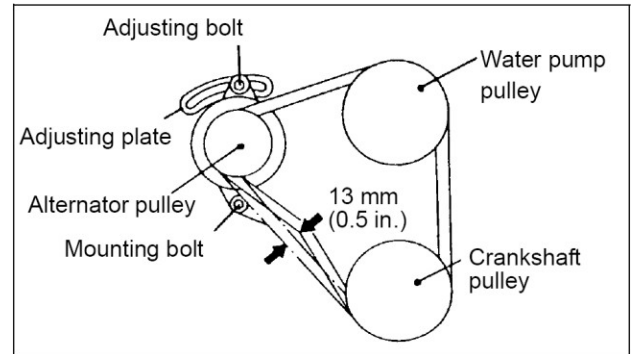

Fig. 22: Tension V-belt

4.3 Regular maintenance

CHECK DAILY:

- Oil level.

Take care the oil level is never below the mark. Do not add oil when the level is still above the mark

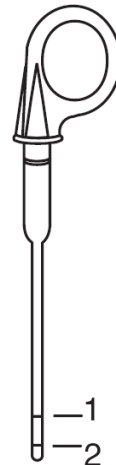

Fig. 23: Engine oil dipstick markings

- Level cooling liquid.
- Hoses for loose connections or deterioration.
- Water inlet filter.
- V-belt tension.

AFTER FIRST 50 HOURS:

- Change oil and replace the oil filter.
Have the engine run until it is on temperature and stop it. Replace the filter. Drain oil by the sump pump into a suitable retainer and fill up with fresh oil. Start the engine again and have it run for 5 minutes. Stop the

engine again and pause for a few minutes to let the oil gather in the crankcase. Check the level again and add oil when necessary.

- Check and tighten nuts, bolts, and unions, paying particular attention to the fuel system.
- Observe the exhaust at the normal full load. The exhaust must be free from soot. Do not allow the engine to run with a dirty exhaust without investigating the cause as this may result in an expensive breakdown.
- Check air vent (siphon breaker valve) on a regular basis. When the air vent is not working properly, the engine can fill up with water by siphoning. Water in the combustion chamber causes serious damage to the engine.
- Check and readjust V-belt.
- Check the electrical connections.

EVERY 150 HOURS:

- Change oil.
- Check the battery acid level (not for WhisperPower batteries).
- Check battery terminals for corrosion.
- Check and readjust V-belt.
- Check impeller raw water pump (durability depends on the purity of the sea water. In sandy water and warm water wear will increase).

When replacing the impeller the gasket between the pump case and the cover should be replaced as well. So when ordering a spare impeller order a gasket as well. Remove the cover to get access to the impeller. Remove the old impeller with the help of two screwdrivers. Install the new impeller and add some grease. Turn the blades in the direction of rotation of the pump.

EVERY 300 HOURS:

- Replace the impeller of the raw water pump.
- Retighten the cylinder head bolts and adjust the valve clearance. (See paragraph 5.4.2).
- Check air cleaner element.
- Replace the oil filter.
- Replace the fuel filter
Replacement depends on the condition of the fuel. We recommend replacement every 300 hours.

EVERY 1000 HOURS:

- Replace the V-belt.
- Retighten cylinder head bolts/adjust + check and adjust valve clearance.

EVERY 2000 HOURS:

- Check lubricating oil pressure.
- Clean and check or replace fuel injector nozzles and check injection pressure.
- Check the air cleaner element:
- The air is taken from the section between the alternator and the engine
- Check the cooling system:

The engine cooling liquid is indirectly cooled by raw water via a heat exchanger. The seawater is pumped by the PTO driven impeller pump. All parts of the cooling system are of corrosion free and seawater resistant materials such as naval brass and copper/nickel. In case of gathering of dirt in the system it could be cleaned by compressed air. When overhauling the engine one could clean the parts thoroughly or replace.

When the generator set runs less than 150 hours a year the oil should be changed yearly.

4.3.1 Maintenance schedule

| | |
|--|----------------------|
| Check oil level | daily |
| Check water inlet filter | daily |
| Check the level of the cooling liquid | daily |
| Check hoses for loose connections or deterioration | daily |
| Change oil and oil filter | after first 50 hours |
| Check and tighten nuts, bolts, etc. | after first 50 hours |
| Check exhaust | after first 50 hours |
| Check air vent | after first 50 hours |
| Check and readjust V-belt | after first 50 hours |
| Check electrical connections | after first 50 hours |
| Change oil | 150 hours |
| Check battery | 150 hours |
| Check air vent | 150 hours |
| Check and readjust V-belt | 150 hours |
| Check impeller water pump | 150 hours |
| Replace impeller water pump | 300 hours |
| Retighten cylinder head bolts and readjust valve clearance | 300 hours |
| Replace oil filter | 300 hours |
| Replace fuel filter | 300 hours |
| Check air cleaner element | 300 hours |
| Retighten cylinder head bolts, adjust valve clearance | 1000 hours |
| Replace the V-belt | 1000 hours |
| Check lubricating oil pressure | 2000 hours |
| Check injector and injection pressure | 2000 hours |
| Check inlet air filter | 2000 hours |
| Check cooling system | 2000 hours |

4.3.2 Taking out of service

When not using the generating set for a longer period it is recommended to execute an engine preservation procedure.

- 1 Clean the engine.
- 2 Loosen the fuel suction pipe and fuel return and put them in a can with preservation diesel fuel. Start the engine and run the engine warm.
- 3 Drain the hot engine oil and refill with preservation oil.
- 4 Stop the engine and take loose the inlet of the raw water pump. Drain the water from the water lock. Crank the

engine having the raw water inlet sucking anti-freeze from a can until the pump, heat exchanger and manifold are filled.

- 5 The coolant can stay in the engine
- 6 Disconnect the battery and store it in a place free of frost and dry and charge it regularly.
- 7 Close inlet- and outlet openings with tape.
- 8 Protect the generating set against the influences of bad weather conditions.

This method of preservation will be sufficient for 6 months.
Change oil before using the engine again.

5 TROUBLESHOOTING

5.1 Alternator/ electrical faults



CAUTION

Remove 3 Amp. Fuse in the control panel while working on the generator to prevent the engine to start.



DANGER!

Take care for parts which are live!

5.1.1 General

If any problem should occur, check basic conditions and examine all external wiring, switch gear and circuit breakers. Also check if measuring instruments give the correct value. If in doubt, measure directly on the alternator terminals with an independent instrument. This should only be carried out by an experienced electrician. If during these measurements the engine immediately stops after starting and an error code is displayed at the remote control panel ("AC VOLTAGE"), one can start the generator by means of a "service start" at the service menu (see paragraph "service start" of the user's manual of the Digital Diesel Control). By doing this, the generator will keep running for 2

minutes before it stops. This offers you the possibility to carry out measurements to investigate the cause of the failure.

Check if the engine is running correctly at 1500 RPM (50 Hz) according to its settings and does as well under load. A RPM drop of 3% at full load is acceptable. Therefore a no load setting should be at 1545 RPM = 51.5 Hz. Under no circumstances should the RPM under full load be below 1485 RPM = 49.5 Hz.

When the problem is in the RPM refer to the engine fault finding paragraph.

Digital Diesel Control system will help to indicate failures and display causes.



CAUTION

If the voltage is set any higher than its maximum limit, the generator may be damaged.

If the bottom speed is set at too low a frequency, the generator may be damaged. On the other hand too high a frequency can cause voltage drops with high loads.

A failure code is displayed when a hardware failure at the generator is detected.

| <i>Failure code</i> | <i>Problem</i> |
|----------------------|--|
| COMMUNICATION | Communication error between the panel and the generator |
| LOW START BAT | Starter battery voltage too low |
| ALTERNATOR | No output battery charging voltage |
| EXHAUST TEMP | Exhaust temperature is too high |
| WATER TEMP | Coolant temperature is too high |
| OIL PRESSURE | Oil pressure failure |
| LOW VOLTAGE | Generator AC output voltage is too low |
| HIGH CURRENT | Generator is in overload |
| FREQUENCY | Output frequency of the generator is too low |
| ECU FAILURE | When red light, fig 24 is blinking →see table pag. 37 (SQ-Pro 18 only) |

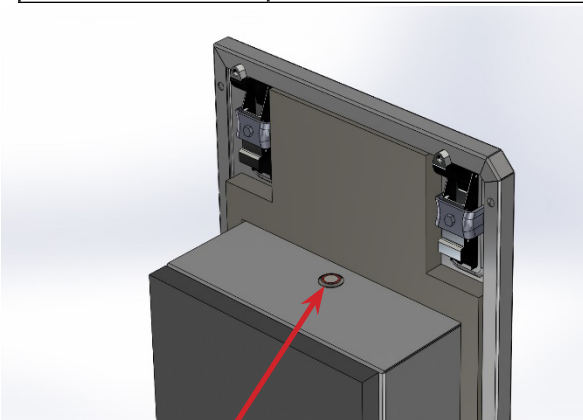











Fig 24 ECU red light

Tabel ECU signal pattern, these patterns can be read out on the red light of fig 24 & 25

| Blinking Pattern of Glow Lamp | Cause | Refer to Checking |
|---|---|--------------------------|
| (1-Long and 1-Short)  3EEAAB1P005A | Overrunning (more than 115 %) | Actuator |
| (1-Long and 3-Short)  3EEAAB1P007A | Defect of alternator | Alternator |
| (1-Long and 4-Short)  3EEAAB1P008A | Coolant temperature is abnormal | Water temperature sensor |
| (2-Long and 1-Short)  3EEAAB1P010A | Abnormality of speed sensor | Speed sensor |
| (2-Long and 2-Short)  3EEAAB1P011A | Actuator malfunction | Actuator |
| (2-Long and 4-Short)  3EEAAB1P012A | Disconnection of water temperature sensor | Water temperature sensor |
| (2-Long and 5-Short)  3EEAAB1P013A | Short circuit of water temperature sensor | Water temperature sensor |
| (2-Long and 6-Short)  3EEAAB1P014A | Disconnection of alternator L Terminal | Alternator L Terminal |
| (2-Long and 7-Short)  3EEAAB1P015A | Excess voltage | Battery |
| (2-Long and 8-Short)  3EEAAB1P016A | Short circuit (option) | (Option parts) |

5.1.2 Troubleshooting table

| PROBLEM | CAUSE | SOLUTION |
|--|--|---|
| No output (Voltage) at all | <ul style="list-style-type: none"> • Circuit breaker “off” or faulty main fuse • Faulty fuse of the AVR | Check switches and fuses and measure directly on the alternator to exclude external causes. Check fuse of the AVR |
| | <ul style="list-style-type: none"> • Loss of residual magnetism | Check the residual magnetism, temporarily increase RPM with 15%. Try to and flash the alternator (see special procedures) |
| | <ul style="list-style-type: none"> • Low engine RPM. | Check the engine RPM and adjust (see special procedures). |
| | <ul style="list-style-type: none"> • Faulty RPM. | Check by independent excitation if the problem is in the AVR or in the windings and replace if necessary (see special procedures). |
| Generator output voltage too low when no load is on it (less than 225V between phase and neutral). | <ul style="list-style-type: none"> • Engine is not reaching the rated RPM. | See special procedures to readjust RPM. |
| | <ul style="list-style-type: none"> • Faulty AVR. When slightly too low, adjustment could be necessary | Try to readjust AVR. Check by independent excitation if the problem is in the AVR or in the windings and replace AVR if necessary (see special procedures). |
| | <ul style="list-style-type: none"> • Defective diode | Check the diode in the rotor (see special procedures). The M-SQ-Pro15/18 has one diode block/rectifier unit. |
| Generator output voltage too low under load (less than 225V). In no load condition it is OK | <ul style="list-style-type: none"> • When applying 3 phase: an unbalanced load; check the voltage of the other phases. When the voltages are different this is caused by an unbalanced load. | Bring load in balance. When slightly out of balance, remove the sense wires to the phase with the highest load and check if the voltage on the other phases is not too high. |
| | <ul style="list-style-type: none"> • Engine is not reaching the rated RPM. Possibly too much load or engine problems (lack of fuel) | Switch off a load; (part off) consumers See to engine RPM problems |
| | <ul style="list-style-type: none"> • Faulty AVR or readjustment necessary | Try to readjust the voltage Check by independent excitation if the problem is in the AVR or in the windings and replace AVR if necessary (see special procedures). |
| Generator output voltage too high, (more than 235V) | <ul style="list-style-type: none"> • Over-energising due to defective AVR or wrong AVR setting | Check AVR, readjust and replace if necessary capacitor specification and replace AVR if necessary (see special procedures). |
| Generator output voltage too high, (more than 235V) In no load condition it is OK | <ul style="list-style-type: none"> • Unbalanced load | Bring load in balance. When slightly out of balance, remove the sense wires to the phase with the highest load and check if the voltage on the other phases is not too low. |
| Generator voltage fluctuates. | <ul style="list-style-type: none"> • Disturbances on the electrical system/ user side. | Check if electrical load is fluctuating |
| | <ul style="list-style-type: none"> • AVR reacts on fluctuating load | Readjust the stability setting on the AVR trimmer “ ST ” |
| | <ul style="list-style-type: none"> • Engine runs irregularly. | When engine runs irregularly see section: “Engine runs irregularly” at the “Engine faults” paragraph. |
| Generator is not able to start an electric motor | <ul style="list-style-type: none"> • If the generator is unable to supply enough power to start an AC electric motor, this is usually because this motor draws too much current during starting As the alternator is very much under- rated the problem will appear by the • engine RPM collapsing | Check the electric motor’s current draw required for starting. This should not exceed the rated generator output current. This could be remedied by using a “soft-start”. Inquire at your nearest WhisperPower dealer or directly at the manufacturer, WhisperPower in the Netherlands. |

5.2 Engine faults



CAUTION!

Remove 3 Amp. fuse in the control panel while working on the generator to prevent the engine from starting.

5.2.1 General

Most electrical problems relating to Voltage or Frequency are due to wrong engine speed.

Note that RPM and Hz are basically the same.

Use the problem solving table to find the cause of a wrong engine speed. When there is no obvious cause one can adjust the RPM (see special procedures).

When the engine is not cranking well, starting problems almost always originate from battery problems or poor battery cable connections.

When the engine is cranking, well starting problems almost always originate from lack of fuel or air bubbles in the fuel pipes.



CAUTION!

When the engine does not start instantly, prolonged cranking can fill up the exhaust system with cooling water because of the water injected exhaust. When the water enters the cylinder through the valves this will bring severe damage to the engine. When the engine does not start and repeated cranking is necessary shut off the seawater inlet. Open the valve immediately after the engine has started.

A failure code is displayed when a hardware failure at the generator is detected.

| Failure code | Problem |
|---------------------|---|
| COMMUNICATION | Communication error between the panel and the generator |
| LOW START BAT | Starter battery voltage too low |
| ALTERNATOR | No output battery charging voltage |
| EXHAUST TEMP | Exhaust temperature is too high |
| WATER TEMP | Coolant temperature is too high |
| OIL PRESSURE | Oil pressure failure |
| LOW VOLTAGE | Generator AC output voltage is too low |
| HIGH CURRENT | generator is in overload |
| FREQUENCY | output frequency of the generator is too low |
| ECU FAILURE | When red light, fig. 25 is blinking → see table page 37(SQ-Pro 18 only) |

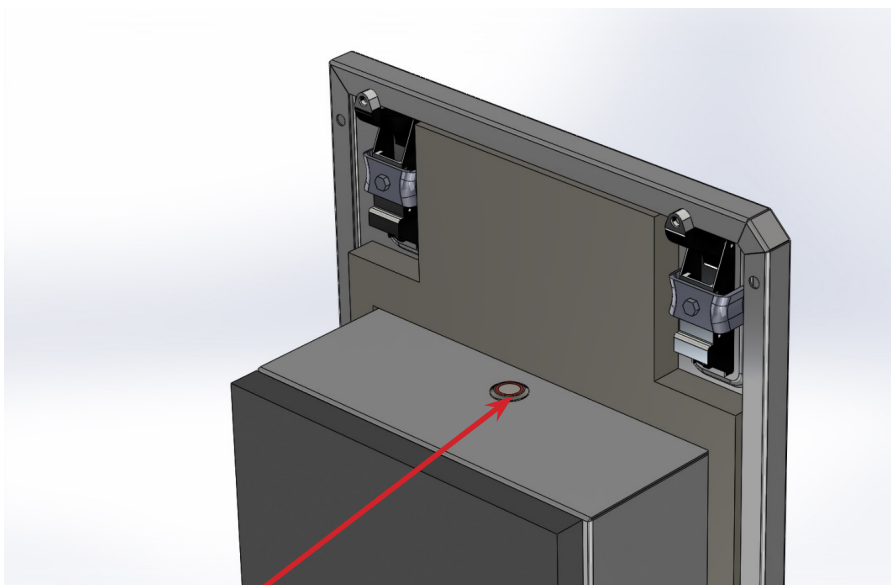

Fig 25 ECU red light

5.2.2 Troubleshooting table

| PROBLEM | CAUSE | SOLUTION |
|--|--|---|
| Diesel engine fails to crank, it does not react at all, or the starter makes clicking noises, or the engine cranks very slowly | <ul style="list-style-type: none"> Almost certainly this is an electrical problem. One other possibility is that the engine is locked by water in the cylinders or there is other severe damage. Display will indicate "low battery voltage". | Check on water in the cylinder and further damage by cranking. When there is water in the cylinder, then deactivate the control system, disconnect the battery, remove the glow plugs. Crank the engine to remove the water through the opening of the glow plugs. Check oil on the presence of water and change oil. Find out how the water did enter the cylinder (check the air vent). Take precautions to prevent it from happening again. When there is no mechanical malfunction the problem must be an electric malfunction. |
| No reaction at all | <ul style="list-style-type: none"> Starter battery switched "OFF". | Check position of the battery switch and switch "ON". |
| | <ul style="list-style-type: none"> Faulty fuse on control panel | Replace fuse |
| No reaction or clicking noises, or slow cranking | <ul style="list-style-type: none"> Starter battery voltage insufficient (battery too weak). | Check battery voltage. Recharge the battery. Inspect battery terminals and cables for a good electrical connection (inspect against corrosion, tattered wires, etc.) |
| | <ul style="list-style-type: none"> Too thick engine lubricating oil. | Change oil for a lower viscosity. |
| Starter is turning engine smoothly, but engine fails to start | <ul style="list-style-type: none"> Starter motor faulty | Repair the starter motor |
| | <ul style="list-style-type: none"> Out of fuel or faulty fuel, water in the fuel. | Fill up with fuel or replace with better quality. |
| | <ul style="list-style-type: none"> Fuel solenoid is not working. | Check if solenoid comes in; if not check wire connections and circuitry to solenoid (see DC wiring diagram). |
| | <ul style="list-style-type: none"> Fuel lift pump is not working. Fuel filter is blocked. Air in fuel lines. | Check fuel filter and fuel lift pump: clean or replace if necessary. Bleed air from fuel system (see maintenance section). |
| | <ul style="list-style-type: none"> Wrong valve clearance. | Adjust valve clearance, |
| | <ul style="list-style-type: none"> Low compression because of dirty valves. | Clean valves. Take off the injection bend and inspect the outlet port. When little rust in the port clean the valve by taking off the valve spring and rotate until clean. When the outlet port is strongly affected by rust, the exhaust system is not properly installed (see paragraph 5.4.3). Contact WhisperPower service department for advice. |
| | <ul style="list-style-type: none"> Blocked injector. | Have the necessary injector tested and cleaned if necessary |
| <ul style="list-style-type: none"> Loss of compression by wear out or damage | Repair by WhisperPower service | |

| | | |
|---|---|--|
| Engine runs irregularly. | <ul style="list-style-type: none"> • Unsuitable contaminated fuel • Lack of fuel. | Fill up with fuel or replace by better quality. |
| | <ul style="list-style-type: none"> • Choked fuel filter. | Check fuel filter and fuel lift pump: clean or replace if necessary. |
| | <ul style="list-style-type: none"> • Disturbances on the electrical system/ user side. | Check if electrical load is fluctuating. |
| | <ul style="list-style-type: none"> • Faulty fuel lift pump. | Try the pump by manual operation. Repair when faulty or replace |
| | <ul style="list-style-type: none"> • Choked air cleaner. • Lack of air. | Check the air intake |
| | <ul style="list-style-type: none"> • Choked exhaust system, exhaust blocked, rubber exhaust hose kinked. | Check the exhaust hose |
| | <ul style="list-style-type: none"> • Air in the fuel pipes | Bleed air from fuel system (see maintenance section). |
| | <ul style="list-style-type: none"> • Blocked injector. | Have the necessary injector tested and cleaned if necessary |
| | <ul style="list-style-type: none"> • Wrong valve clearance. | Adjust valve clearance. |
| | <ul style="list-style-type: none"> • Temporarily hunting (this will disappear when engine has run in). | |
| Engine speed drops | <ul style="list-style-type: none"> • Too much oil. | Drain oil to proper level. |
| | <ul style="list-style-type: none"> • Lack of fuel. | Check fuel supply system: fuel pump and filter. |
| | <ul style="list-style-type: none"> • Lack of intake air. | Check air intake. |
| | <ul style="list-style-type: none"> • Choked exhaust system, exhaust blocked, rubber exhaust hose kinked. | Check exhaust system. |
| | <ul style="list-style-type: none"> • Generator overloaded | Reduce the electrical load (switch off some consumers). |
| | <ul style="list-style-type: none"> • Defective generator (windings, bearings or other) | Generator must be sent to manufacturer for repair of damaged bearing or winding. |
| | <ul style="list-style-type: none"> • Damaged engine | Repair by WhisperPower service |
| Engine does command not stop on command | <ul style="list-style-type: none"> • Fuel solenoid is not switching off • Loss of control | Faulty Digital Diesel Control unit. Stop the engine manually by the stop handle. Check wire connections to fuel solenoid. Check solenoid function. Replace if necessary |
| Engine exhaust smokes | <ul style="list-style-type: none"> • Faint blue smoke- generally the result of light load | Increase load. |
| | <ul style="list-style-type: none"> • Heavy blue smoke- caused by lubricating oil: Overfull oil sump or worn cylinder bore, stuck broken or worn piston rings. | Check the oil level. Check the compression. |
| | <ul style="list-style-type: none"> • Black smoke –incomplete combustion caused by: Overload, choked air cleaner, inlet temperature too high, unsuitable fuel or water in fuel. | Check air cleaner Check the fuel . Check for overload. |
| Engine starts, but stops after 10 seconds | <ul style="list-style-type: none"> • Protection system stops the engine; this can be caused by oil pressure failure, lack of cooling water (exhaust temperature alarm). Overload, loose wire or faulty alarm switch. Digital Diesel Control will help to indicate failure. | See paragraph 2.5.5. and 3.2.2 for information on the alarm system. Bypassing the switches can help to confirm the failure. When there is no real failure, it could be a faulty alarm switch |

| | | |
|---|---|---|
| Engine stops by itself (Digital Diesel Control will help to indicate failures) | <ul style="list-style-type: none"> • Overload or short circuit. • Lack of fuel. | Switch off the consumers and test for short circuit. Check fuel supply system: fuel lines, pump, filter, valves, tank level, etc. |
| | <ul style="list-style-type: none"> • Oil pressure low. (oil pressure switch tripped). | Check oil level. Check engine's oil pressure and have it repaired by WhisperPower. |
| | <ul style="list-style-type: none"> • Excessive heat in cooling system (thermo-switch tripped). • Lack of cooling water (exhaust switch tripped). • Impeller broken. • Cooling water blocked. • Water strainer blocked. • Air or water in the fuel. • Blocked air or fuel filter. | Check cooling water system flow: water pump, inlet water filter, coolant flow. |
| | <ul style="list-style-type: none"> • Loss of compression by wear out or damage. | Repair by WhisperPower service. |
| | <ul style="list-style-type: none"> • V-belt broken or loose. | Readjust or replace V-belt |
| | <ul style="list-style-type: none"> • Thermostat faulty | Check thermostat and replace |
| Sooty, black exhaust. | <ul style="list-style-type: none"> • Generator is being overloaded. Digital Diesel Control will indicate "overload". | Check electrical load and switch off some consumers |
| | <ul style="list-style-type: none"> • Insufficient intake air. • Choked air cleaner. | Check intake air paths and filter, clean and replace if necessary. |
| | <ul style="list-style-type: none"> • Fuel injector faulty. | Replace injector. |
| | <ul style="list-style-type: none"> • Valve clearance incorrect. | Readjust valve clearance |
| | <ul style="list-style-type: none"> • Poor fuel quality. | Use better quality diesel. |
| | <ul style="list-style-type: none"> • Poor quality lubricating oil. | Use better quality oil. |
| | <ul style="list-style-type: none"> • Continuous running with very low load. | Increase load and have the engine run for a few hours |
| Loss of power | <ul style="list-style-type: none"> • Wrong measurement. Check if the load is measured correctly. Does the Amp meter show the correct value? When calculating the load by multiplying voltage and amps this should be done by using the exact values, taking into account the power factor of the consumers. When any doubt, measure the power directly with an appropriate instrument. | |
| | <ul style="list-style-type: none"> • Overfull oil sump. | Bring the oil to the correct level |
| | <ul style="list-style-type: none"> • Choked fuel filter. | Replace the fuel filter. |
| | <ul style="list-style-type: none"> • Choked air cleaner | Check air inlet openings; clean air cleaner. |
| | <ul style="list-style-type: none"> • Exhaust blocked. | Check the exhaust system. |
| | <ul style="list-style-type: none"> • Injector blocked. | Have the injector checked. |
| | <ul style="list-style-type: none"> • Loss of compression, sticking or damaged piston ring. | Have the compression measured. Clean or replace the rings. |
| <ul style="list-style-type: none"> • Wear out of cylinder. | Have the compression measured and have the engine overhauled. | |
| Over-temperature | <ul style="list-style-type: none"> • Overload. | Take away the overload. |
| | <ul style="list-style-type: none"> • Low level of cooling oil or air in the cooling system | Fill up with liquid and release air bubbles. Check if there are air blocks in the system; see the installation manual |
| | <ul style="list-style-type: none"> • Water inlet system blocked. • Broken impeller. • Water strainer choked • Heat exchanger choked. | Check the cooling system thoroughly. |
| | <ul style="list-style-type: none"> • Faulty thermostat | Check the thermostat or replace. |

5.2.3 Warnings



CAUTION!
Generator must be shut off immediately if:

- Motor RPM suddenly rises or drops.
- Unusual noise comes from generating set.
- Exhaust gases suddenly colour dark.
- Engine failure warning light is on.

5.2.4 Service address

If you cannot correct a problem with the aid of the malfunction table, contact your WhisperPower Service Centre or WhisperPower Netherlands, tel: INT+31-512-571555. www.whisperpower.com.

5.3 Special procedures alternator

5.3.1 Automatic Voltage Regulator (AVR)

The voltage regulator has a $\pm 1\%$ voltage precision in the machine working range with distortion free loads.

The phase voltage can be adjusted by trimmer "VG" (see figure 24).

A fuse protects the regulator and generator against overloads and/or faults; a pocket has been provided on the edge of the board to hold a spare fuse (rapid type 32x6.3 2A).

Another trimmer "ST" allows to adapt the regulator to the generator parameters.

The regulator has been built to suppress the voltage surges on releasing the load that are below 20% at nominal load.

AVR SETTINGS

To select the AVR settings access the control board after removing the cover. Most adjustments are factory set to ensure satisfactory results in the operating tests on commissioning. Further adjustments may be necessary to ensure optimum operation under specific working conditions.

Normally the alternator operate at 50Hz. When operating at 60Hz connect terminals 6 and 7 of the HVR-11 regulator with a bridge.

The output voltage can be changed by adjusting potentiometer "VG". Take the generating set to its nominal speed and turn until the required voltage is obtained

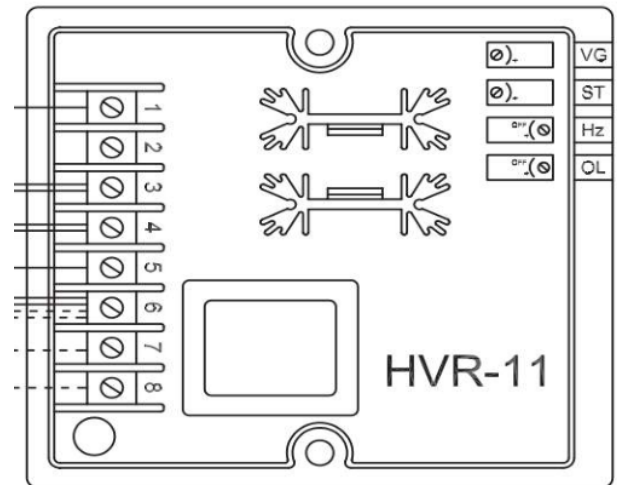

Fig 26: Automatic Voltage Regulator (AVR)

Setting the bottom speed at 50 (60)Hz: start up rotation of the generating set adjusting it to obtain a frequency of 46 (56) Hz. Turn trimmer "Hz" until the voltage begins to drop. Restore nominal speed.



CAUTION!

If the bottom speed is set at too low a frequency the generator may be damaged. On the other hand, too high a frequency can cause voltage drops with high load.

5.3.2 Residual voltage check / excitation procedure (flashing)

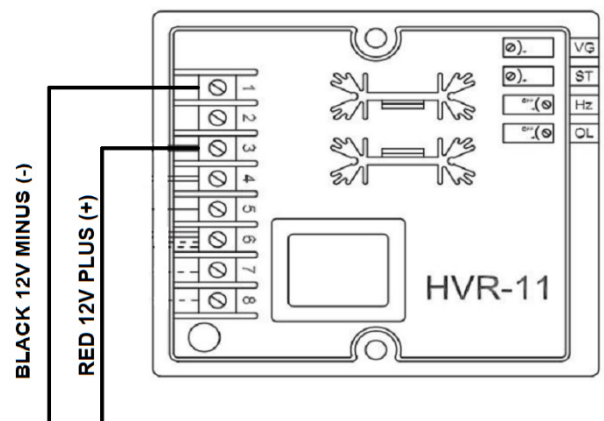

Fig. 27: Residual voltage check / excitation procedure

When residual magnetism disappears there is no residual voltage. Residual magnetism can disappear after the generating set being out of service for a long period or a short circuit. This can be solved by exciting the exciter field coil directly, disconnecting the AVR first. Put 12 Volt directly over the electronic regulator terminals taking polarity into account.

When using the starter battery fuse it and limit the current with a 30 Ohm resistor. Flashing can be done while the engine is running and the wiring is connected. When a variac (variable power supply) is available one should be able to control the voltage manually.



CAUTION

If the starter set battery is used for exciting one must take care. A short circuit can cause heavy sparking, fire and injuries.

When external excitation does not bring back voltage, the rotating rectifier diodes should be tested and a winding resistant test should be executed.

5.3.3 Testing rotary rectifier diodes

The diodes in the rotor can be checked with a multimeter. The diodes are integrated in a rectifier unit. When all diodes are faulty the alternator will not generate any voltage. When one or more diodes are faulty the alternator will produce too low voltage.

The flexible leads connected to the diodes should be disconnected at the terminal end, and the forward and reverse resistance checked. A healthy diode will indicate a very high resistance (infinity) in the reverse direction, and a low resistance in the forward direction. A faulty diode will give a full deflection reading in both directions with the test meter on the 10,000 ohms scale, or an infinity reading in both directions. In case of faulty diodes replace the rectifier unit. One can get access to the diode unit by taking off the backend of the alternator.

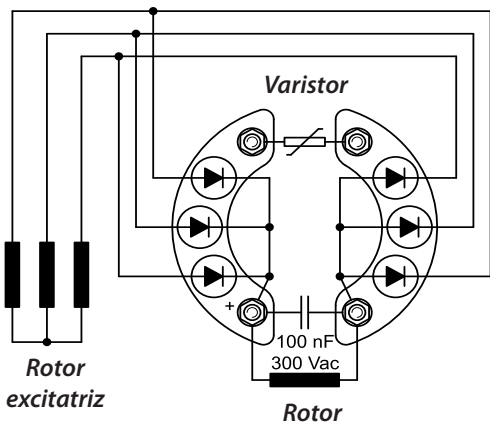

Fig. 26: Location rectifier diode block

5.3.4 Winding resistant values

If after establishing and correcting any fault on the AVR and diodes, and output is still low when separately excited, then the main rotor, stator auxiliary and exciter stator winding

resistance should be checked as the fault must be in one of these windings. The respective leads must be disconnected before taking the readings.

Resistance values should be within 10% of the values given in the table below:

Resistance M-SQ-Pro15/18

| Alternator Winding resistant | SQ-Pro 15 1phase | SQ-Pro 15 3phase | SQ-Pro 18 1phase | SQ-Pro 18 3phase |
|------------------------------|------------------|------------------|------------------|------------------|
| Stator Windings Resistance Ω | 0,12 | 0,325 | 0,08 | 0,224 |
| Rotor Windings Resistance Ω | 2,43 | 2,22 | 1,67 | 2,43 |
| Exciter Stator Resistance Ω | 15 | 15 | 11,05 | 15 |
| Exciter Rotor Resistance Ω | 0,72 | 0,72 | 0,32 | 0,72 |

5.3.5 Meggering

One can try to measure resistance between the housing and the windings with a multimeter which should read infinity. When readings are infinity but a fault is suspected one can do a high voltage resistance test (MEGGERING) This procedure should be carried out by an expert. The AVR should be disconnected during this test. A 500V 'Megger' or similar instrument should be used. The insulation resistance to earth of all windings should be in excess of 2 MOhm. Should the insulation resistance be less than this value, drying out the generator windings is essential. Drying out can be carried out by direct warm air (60-80°C) from a fan heater or similar apparatus into the generator air inlets or outlets.

5.4 Special procedures engine

5.4.1 Setting the RPM

RPM is set by the manufacturer and should not need readjustment! The RPM of the W-SQ-Pro 18 is controlled digitally by the ECU and does not needs readjustment. A throttle lever is present on the W-SQ-Pro 15. If readjustment of the throttle lever is necessary, please contact your WhisperPower Service Centre for advice.

5.4.2 Adjusting valve clearance and retightening the cylinder head bolts

Both procedures have to be executed with a cold engine. When both procedures are executed be sure to retighten the cylinder head bolts before adjusting the valve clearance. When retightening the cylinder head bolts, drain the coolant by removing the coolant drain plug

Loosen the bolts slightly, remove the rocker assembly (the rocker arms, shaft, and stays) and then retighten the bolts to the specified torque in the numerical order illustrated (ref. to fig. 28).

V1505

| | |
|---------------------------------------|-----------|
| Tightening torque cylinder head bolt: | 65 ± 5 Nm |
| Rocker stay tightening torque: | 23 ± 2 Nm |

V2203

| | |
|---------------------------------------|-----------|
| Tightening torque cylinder head bolt: | 95 ± 5 Nm |
| Rocker stay tightening torque: | 25 ± 2 Nm |

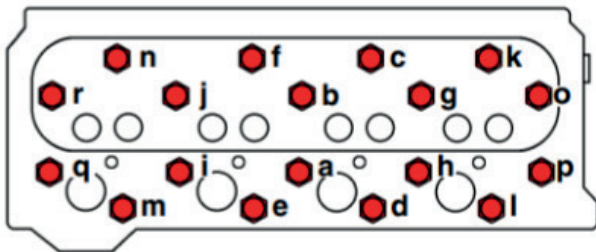

Fig. 28: Cylinder head bolt tensioning sequence

The clearance of both (intake and exhaust) valves should be 0.25 mm in cold condition. Set the piston of the first cylinder to be adjusted to top dead centre (T.D.C.) of compression stroke.

The T.D.C. of compression stroke can be found by aligning the T.D.C. mark "O" on the crankshaft pulley with the mark on the gear case

First align the T.D.C. mark for the No. 1 cylinder. Confirm that the valves do not move up or down when the crankshaft is turned about 20 degrees in normal and reverse direction of rotation.

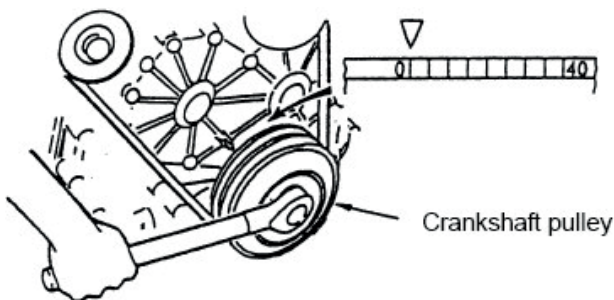

Fig. 29: Checking valve clearance (turning)

If the rocker arms move piston no.1 is on the T.D.C. of the intake or exhaust stroke. In such case turn the crankshaft 360° in the direction of engine rotation again. No. 1 piston is now at T.D.C. of the compression stroke.

After adjusting the valves of cylinder 1 adjust the valve clearance of the remaining cylinders in firing order 1-3-4-2 Turn the crankshaft 180° clockwise from the T.D.C of cylinder 1 to the T.D.C of cylinder 3. Adjusts the valves of cylinder 3 and turn the crankshaft further clockwise to the T.D.C of cylinder 4 and finally to 2.

5.4.3 Measuring exhaust backpressure

The exhaust system must be of adequate size-1 1/2"/ 50 mm- and maximal length (see installation manual). When any doubt, backpressure has to be measured. An easy way to measure for back-pressure is to use a water column.

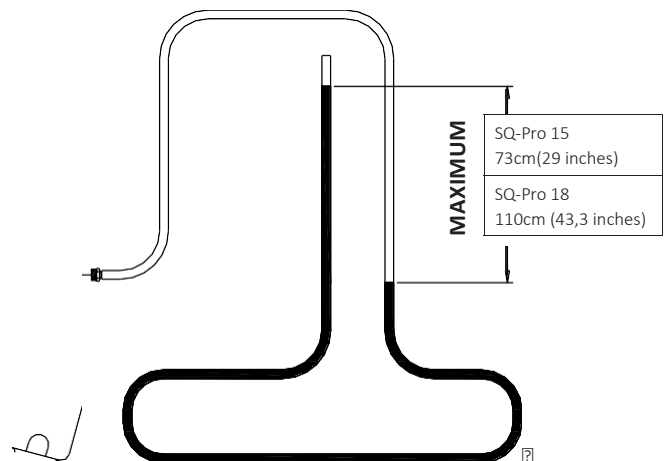

Fig. 30: Measuring exhaust backpressure

A water column can be made visible in a plastic tube along a yardstick and fitting the end to a hose connection to fit in the adaptor on the injection bend after removing the exhaust temperature switch.

The bend A hanging down should not be too short helping to damp the pulsating effect of the gas discharge. The water column should be no more than 27 inches (69 cm.) of water (1 PSI- 0,07 bar).

5.4.4 Disassembling instructions

It could be necessary for repair or checks to disassemble the generating set.

Following instructions will help:

1. The design of the M-SQ-Pro15/18 makes it possible to do most repairs on the spot. The heat exchanger is accessible and can be removed. The connections of the alternator are very accessible as well.
2. The sound shield canopy can be disassembled according to exploded view below.

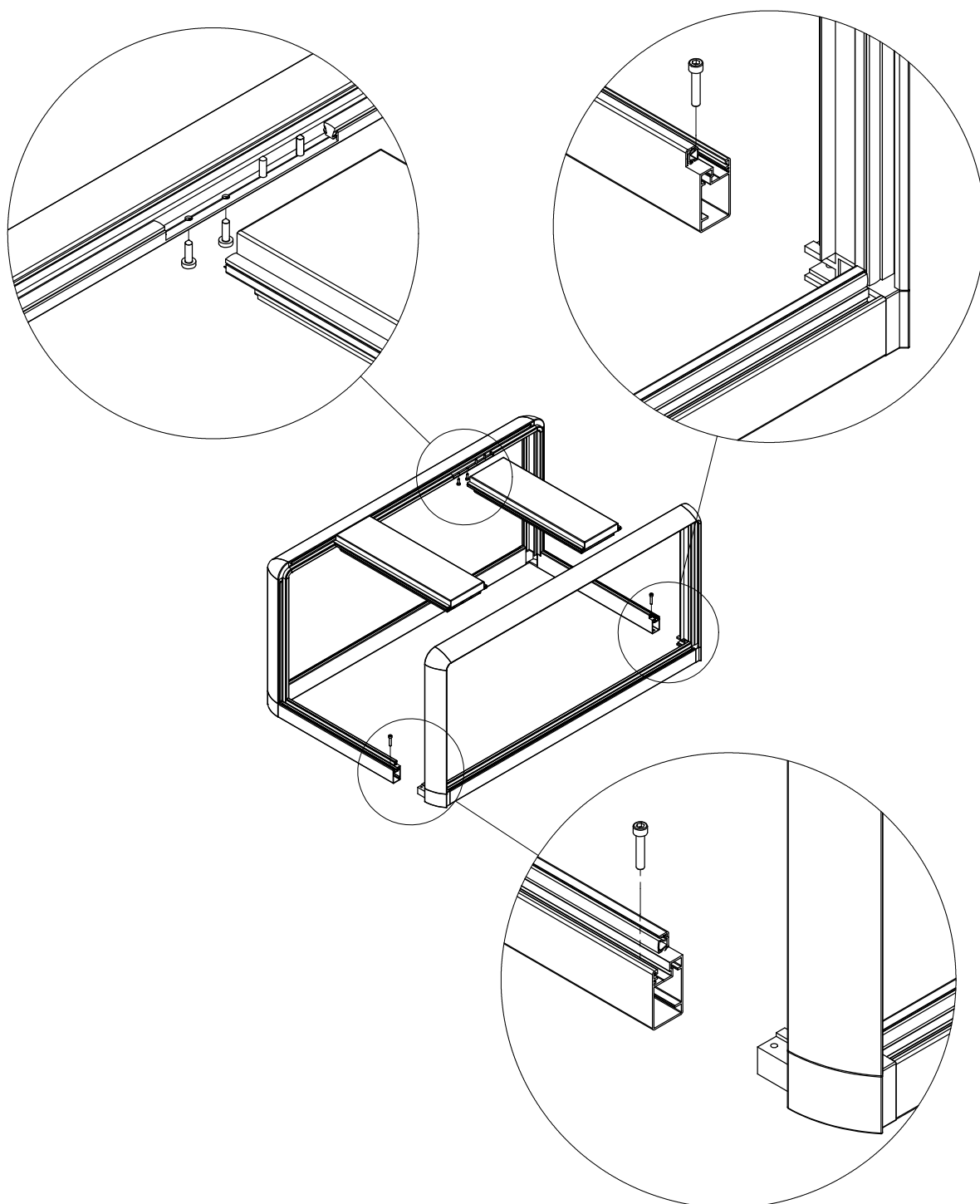

Fig. 31: Exploded view soundshield

1. To take the generating set out of the canopy all hose and cable connections have to be taken off. The set is fixed to its base by four rubber mountings and can be loosened by removing the four bolts of these mountings. The easiest way to get the generator out of its capsule is by lifting the set with the aid of the lifting eyes
2. Taking the generator set from its mounting, or to replace a mounting can be done according to the drawing below
3. Reassembling the generating set one should take care of alignment, cleaning the surfaces between engine and alternator and tighten the bolts crosswise and gradually.
4. Test the generating set first outside its capsule and check very carefully for leakages before putting it back in its enclosure.

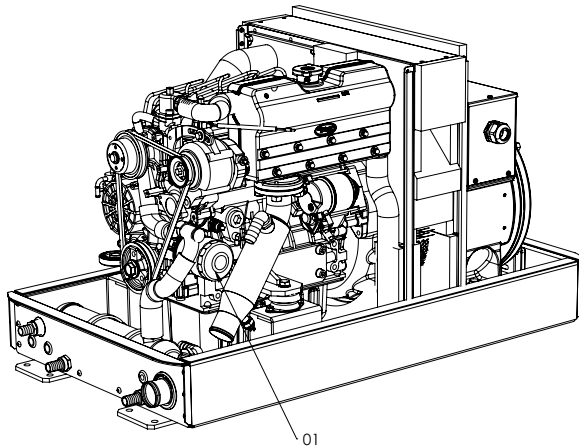

Fig. 32: Exploded view rubber mountings

6 SPARE PARTS

A complete parts manual in English is available as an option number: number: 40200187 (***) A work shop manual in English is available as an option, number: 40200174 (***)

We recommend the following spares for service and maintenance.

Kit A: Article no. 40201560

Kit B: Article no. 42401461

| 42401460 Spare Parts Kit-A SQ-Pro 15 | | | |
|---|--------------------------------------|-----------------|----------------------|
| Article no. | Description | Quantity | Quantity unit |
| 40209030 | Fuel Filter WP | 1 | ST |
| 40405121 | Oil filter GV15 / GV3 PLUS / SQ15- K | 1 | ST |
| 50212170 | Plug fuse 10A 32V ROOD | 1 | ST |
| 50212154 | Plug fuse 3A 32V VIOLET | 1 | ST |
| 40406120 | V belt SQ-Pro 15 | 1 | ST |

| 42401461 Spare Parts Kit-B SQ-Pro 15 | | | |
|---|---|-----------------|----------------------|
| Article no. | Description | Quantity | Quantity unit |
| 40209030 | Fuel Filter WP | 1 | ST |
| 50201168 | Fuel feed pump heavy duty | 1 | ST |
| 40403140 | Glow plug Z482/D722/V1505 K | 4 | ST |
| 40406137 | Valve cover Gasket SQ15 PRO | 1 | ST |
| 40406150 | Nozzle Injector SQ-Pro 15 | 4 | ST |
| 50209212 | Oil Pressure Switch 0,5Bar – single pole adjust | 1 | ST |
| 40405121 | Oil filter GV15 / GV3 PLUS / SQ15- K | 1 | ST |
| 40403138 | Gasket Thermostat housing GV2/SQ15 PRO K | 1 | ST |
| 40201634 | Gasket Injector GV15 / GV3 PLUS / SQ-Pro 15 | 4 | ST |
| 50212170 | Plug fuse 10A 32V ROOD | 1 | ST |
| 50212154 | Plug fuse 3A 32V VIOLET | 1 | ST |
| 40406120 | V belt SQ-Pro 15 | 1 | ST |
| 50209243 | Temperature switch 110°C M16X1.5 NC assy | 1 | ST |
| 40201645 | Thermostat GV15 / GV3 PLUS / SQ-Pro 15 | 1 | ST |

| 42401360 Spare Parts Kit-A SQ-Pro 18 | | | |
|---|-------------------------|-----------------|----------------------|
| Article no. | Description | Quantity | Quantity unit |
| 40209030 | Fuel Filter WP | 1 | ST |
| 40406121 | Oil filter D1703/V2203 | 1 | ST |
| 50212170 | Plug fuse 10A 32V ROOD | 1 | ST |
| 50212154 | Plug fuse 3A 32V VIOLET | 1 | ST |
| 40408120 | V belt SQ-Pro 18 | 1 | ST |

You can find a more extensive Parts List on our website: whisperpower.com (fast moving parts)

6.1 40201670 Raw Water Pump SQ-Pro 15

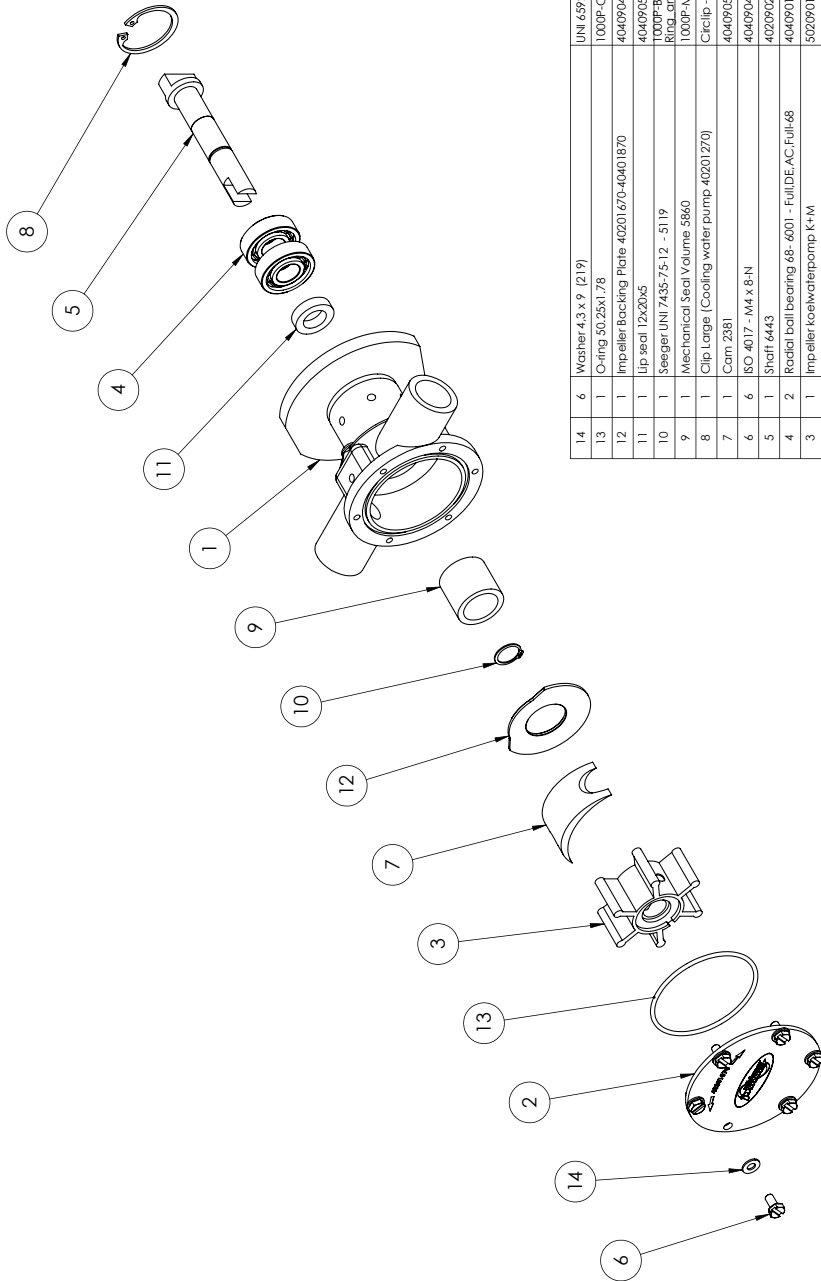

| ITEM NO. | QTY. | DESCRIPTION | FINISH: | SCALE | ARTICLE NO. |
|----------|------|--|-------------------------|----------------------|---------------------------------|
| 14 | 6 | Washer 4.3 x 9 [2]9 | ISO 9013 | DO NOT SCALE DRAWING | NOT REQUIRED |
| 13 | 1 | O-ring 50.25x1.78 | ISO 9013 | SHEET FORMAT: | 40201670 |
| 12 | 1 | Impeller Backing Plate 40201670-40401870 | PROJECTION: THIRD ANGLE | A3 | 40409042 |
| 11 | 1 | Lip seal 12x20x5 | UNIT: mm | TITLE: | 40409051 |
| 10 | 1 | Seeger UNI 7435-7.5-12 - 5119 | MATERIAL: | | 1000P-Base Mechanical Retaining |
| 9 | 1 | Mechanical Seal Volume 5860 | | | 1000P-Mechanical Seal Volume |
| 8 | 1 | Clip Large [Cooling water pump 40201270] | | | 40409016 |
| 7 | 1 | Cam 2381 | | | 40409050 |
| 6 | 6 | ISO 4017 - M4 x 8-N | | | 40409046 |
| 5 | 1 | Shaft 6443 | | | 40209024 |
| 4 | 2 | Radial ball bearing 68-6001 - Full DE.AC-Full-68 | | | 40409014 |
| 3 | 1 | Impeller koelwaterpomp K+M | | | 50209013 |
| 2 | 1 | Cover 6363 | | | 40201401 |
| 1 | 1 | Pump Case 6553 | | | 40201670 corpo WH KUBO/A |
| | | | | | NOT REQUIRED |
| | | | | | NOT REQUIRED |

| | | | |
|-----------------------------|-------------------------|----------------------|-------------|
| UNLESS OTHERWISE SPECIFIED: | FINISH: | SCALE: | ARTICLE NO. |
| CHARMETS SURFACES | ISO 9013 | DO NOT SCALE DRAWING | |
| FORM AND PLACE TOLERANCES | PROJECTION: THIRD ANGLE | SHEET FORMAT: | |
| ISO 2768-mS | UNIT: mm | A3 | |
| WELDING: EN ISO 5817 | MATERIAL: | TITLE: | |
| ROUWNESS ACC. TO NEN 6384 | | | |

| | | | |
|------------|---------------|--------------------|---------------|
| NAME: | DATE: | STATUS: | Design Review |
| SIGNATURE: | 12/3/2021 | | |
| J.K. | 20/7/2020 | | |
| DRAWING: | 7/512A/152962 | | |
| PRINTED: | 31/3/2021 | Weight: 10.19 gram | |

| | |
|-------------|--------------|
| ARTICLE NO. | 40201670 |
| REVISION | |
| SCALE: 1:2 | SHEET 1 OF 1 |

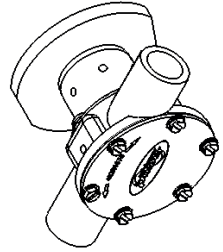

Water Pump Kub D11105-V1 505

6.2 42401870 Raw Water Pump SQ-Pro 18

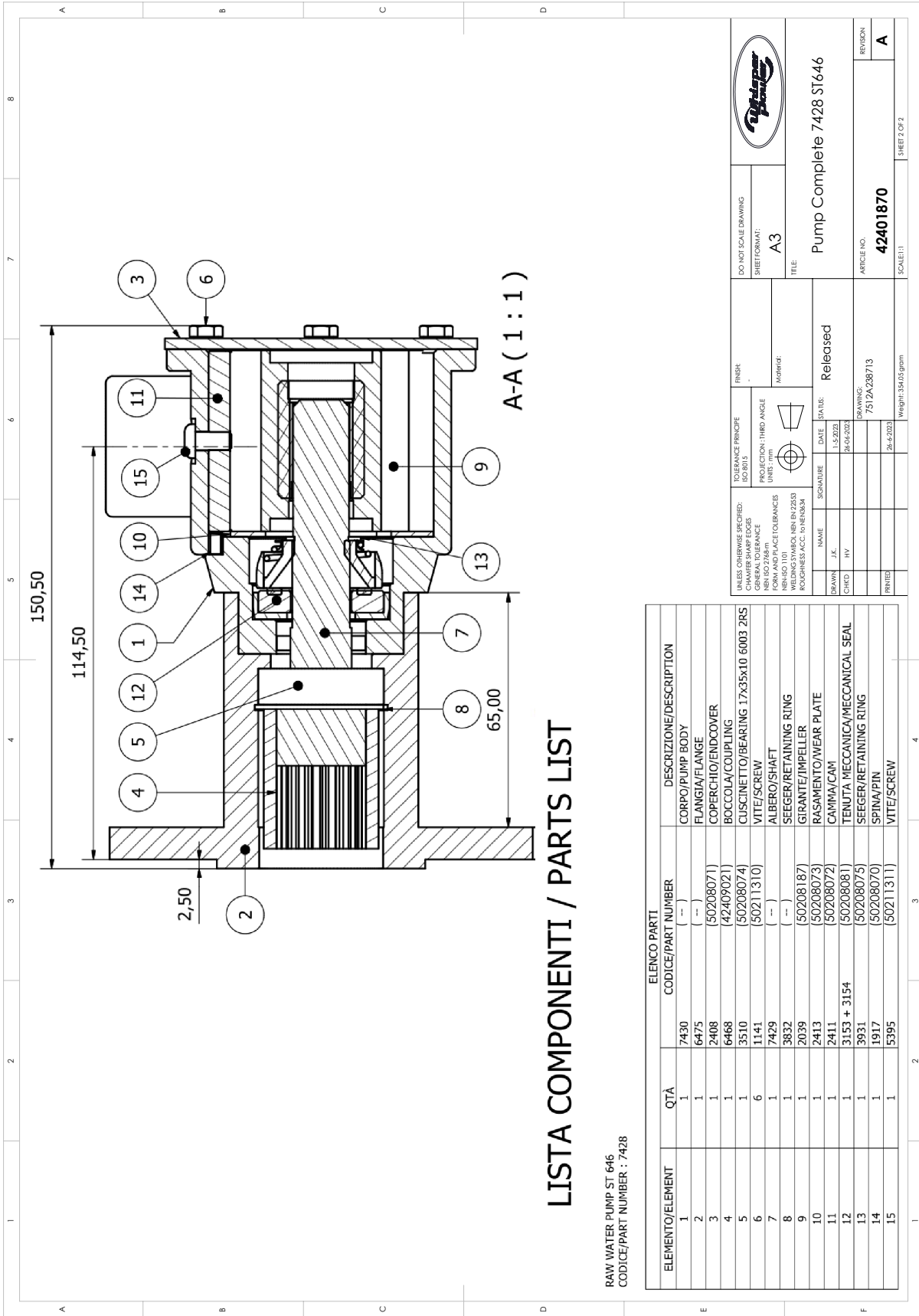

LISTA COMPONENTI / PARTS LIST

RAW WATER PUMP ST 646
 CODICE/PART NUMBER : 7428

| ELEMENTO/ELEMENT | QTA | CODICE/PART NUMBER | DESCRIZIONE/DESCRIPTION |
|------------------|-----|--------------------|--------------------------------------|
| 1 | 1 | 7430 | CORPO/PUMP BODY |
| 2 | 1 | 6475 | FLANGIA/FLANGE |
| 3 | 1 | 50208071 | COPERCHIO/ENDCOVER |
| 4 | 1 | 424090211 | BOCCOLA/COUPLING |
| 5 | 1 | 50208074 | CUSCINETTO/BEARING 17x35x10 6003 2RS |
| 6 | 6 | 50211310 | VITE/SCREW |
| 7 | 1 | 7429 | ALBERO/SHAFT |
| 8 | 1 | 3832 | SEEGER/RETAINING RING |
| 9 | 1 | 2039 | GIRANTE/IMPELLER |
| 10 | 1 | 2413 | RASAMENTO/WEAR PLATE |
| 11 | 1 | 2411 | CAMMA/CAM |
| 12 | 1 | 3153 + 3154 | TENUTA MECCANICA/MECHANICAL SEAL |
| 13 | 1 | 3931 | SEEGER/RETAINING RING |
| 14 | 1 | 1917 | SPINA/PIN |
| 15 | 1 | 5395 | VITE/SCREW |

| | | |
|--|---|--|
| UNLESS OTHERWISE SPECIFIED: GENERAL TOLERANCES FINISH AND SURFACE TOLERANCES DIMENSIONS IN MILLIMETERS UNITS: mm FINISH: A3 TOLERANCE PRINCIPLE: ISO 28015 FINISH: THIRDO ANGLE UNITS: mm MATERIAL: | | DO NOT SCALE DRAWING SHEET FORWARD: A3 TITLE: Pump Complete 7428 ST646 |
| SIGNATURE: _____ NAME: _____ DATE: _____ STATUS: Released | DRAWN: RV CHECK: _____ DATE: 26-6-2023 DRAWING NO.: 7512A238713 WEIGHT: 364,05 gram | ARTICLE NO.: 42401870 REVISION: A SCALE: 1:1 SHEET 2 OF 2 |

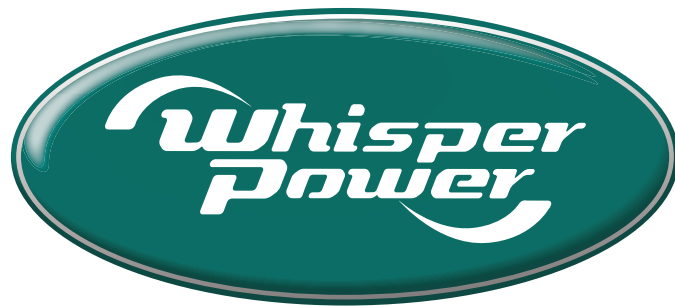

Enjoy Green Energy

WhisperPower BV

Kelvinlaan 82,
9207 JB Drachten
The Netherlands

www.whisperpower.com
sales@whisperpower.com